

# 66 Series, TSP

## High Pressure Triplex Plunger Pump

### FEATURES

- Compact, High Pressure
- Oversized roller bearings
- Fully anodized crankcase
- Innovative new seal design extends seal life
- New plunger design improves “thermal shock” resistance
- New valve cap design improves hydrostatic performance
- Also available in “L” left-handed versions



### SPECIFICATIONS

Pump Model	TSP1619	TSP1619 Alternate Spec	TSP1621	TSP1819	TSP1821
Maximum GPM	3.6	4.3	4.3	5.0	5.5
Maximum PSI	7250	5800	6525	5100	
Horsepower	17.8 EBHP	17.0 EBHP	19.2 EBHP	17.5 EBHP	19.2 EBHP
Maximum RPM	1450	1750	1450		
Inlet PSI Maximum (Minimum)	125 PSI (30 PSI)				
Plunger Bore (mm)	.629 (16)	.629 (16)	.629 (16)	.709 (18)	.709 (18)
Plunger Stroke (mm)	.748 (19)	.748 (19)	.826 (21)	.748 (19)	.826 (21)
Oil Capacity	37.2 oz				
Maximum Fluid Temperature	165°F				
Inlet Port Thread	1/2" BSP-F				
Discharge Port Thread	3/8" BSP-F				
Shaft Diameter (mm)	.945 (24)				
Weight lb(kg)	51.8 (18.5)				
Dimensions	13.8 x 9.8 x 7.7 in				

### DIMENSIONS

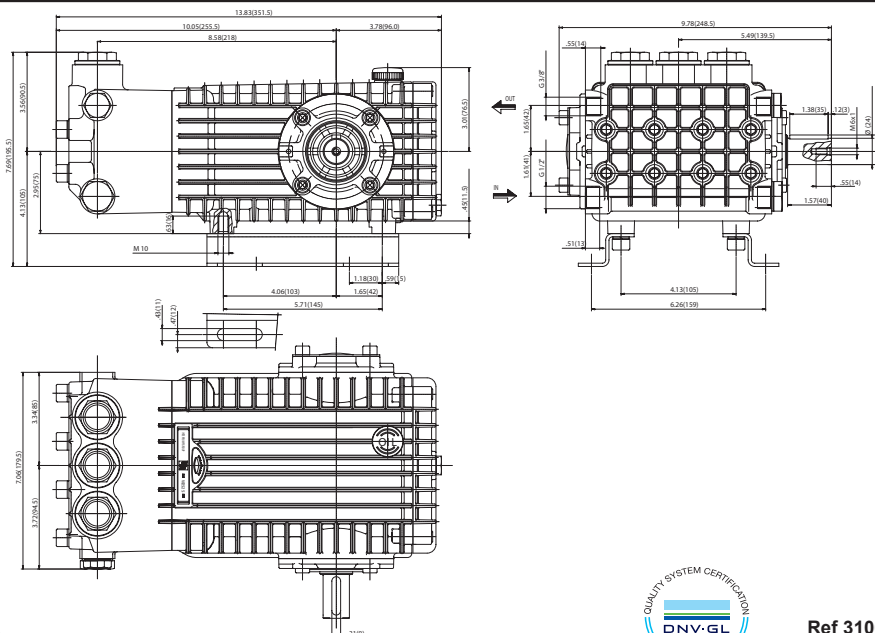

TRIPLEX

TRIPLEX



General Pump  
is a member of  
the Interpump Group



Ref 310046 Rev. N  
04-19



# 66 Series, TSP

**GENERAL PUMP**

A member of the Interpump Group

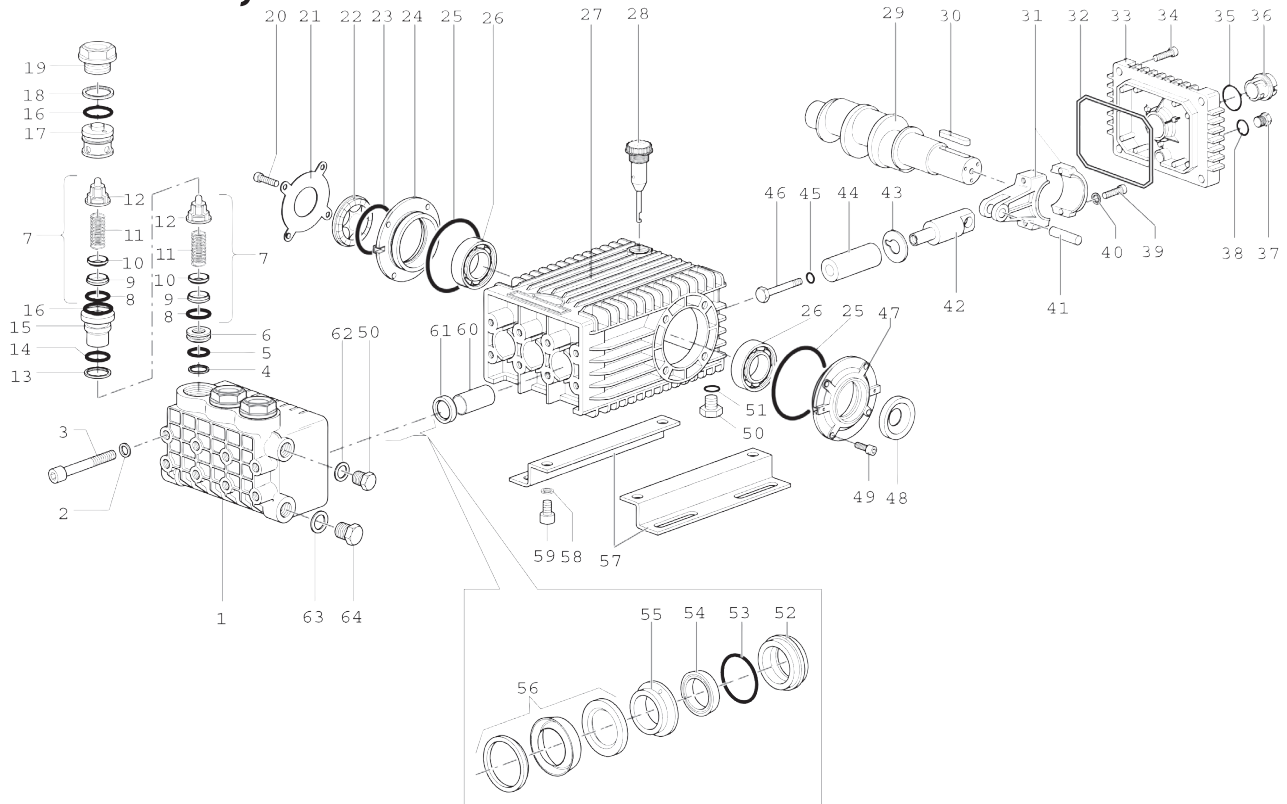

## REPAIR KITS

ITEM	PART NO.	DESCRIPTION	QTY.	ITEM	PART NO.	DESCRIPTION	QTY.	ITEM	PART NO.	DESCRIPTION	QTY.
1.	66121041	Manifold 16mm	1	24.	66150122	Side Cover	2	45.	701013	O-ring 10.82 x 1.78	3
	66121141	Manifold 18mm	1	25.	701147	O-ring 67.95 x 2.62	2			<b>ITEM PART NO. DESCRIPTION QTY.</b>	
2.	96710400	Washer M10	8	26.	91838000	Bearing	1	46.	66219566	Plunger Bolt	3
3.	99382000	Headbolt M10 x 120	8	27.	66010022	Crankcase	1	47.	66150022	Side Cover, PTO	1
4.	90511800	Anti-ext ring	3	28.	98210600	Dipstick, vented	1	48.	90164800	Seal, Shaft 30 x 55 x 7	1
5.	90359600	O-ring 18.77 x 1.78	3	29.	66020435	Crankshaft TSP1621	1	49.	99303900	Screw M8 x 16	4
6.	66210270	Spacer M12	3		66020035	Crankshaft TSP1819	1	50.	98210000	Plug 3/8 x 13	2
7.	36712101	Valve Assy.. Complete	6	30.	91489200	Key	1	51.	90383300	O-ring 13.95 x 2.62	1
8.	701115	O-ring 17.13 x 2.62	6	31.	66030001	Connecting Rod	3	52.	66080270	Seal Retainer 16mm	3
9.	36200366	Valve Seat	6	32.	90392200	O-ring 133.02 x 2.62	1		66080370	Seal Retainer 18mm	
10.	36203266	Valve Poppet	6	33.	66160022	Cover, Crankcase	1	53.	90361600	O-ring 34.65 x 1.78	3
11.	94737600	Valve Spring	6	34.	99188400	Screw M6 x 20	4	54.	90263100	LP Seal 16mm	3
12.	36202551	Valve Guide	6	35.	90405100	O-ring 26.58 x 3.53	1		90265200	LP Seal 18mm	
13.	90511500	Anti-ext ring	3	36.	63210051	Sightglass, Bayonet style	1	55.	66216270	Intermediate Ring 16mm	3
14.	90384300	O-ring 17.86 x 2.62	3	37.	98204100	Plug, G1/4" x 9	1		66216370	Intermediate Ring 18mm	
15.	66210166	Bushing	3	38.	701013	O-ring 10.82 x 1.78	1	56.	90263400	HP Seal 16mm	3
16.	90385700	O-ring 23.81 x 2.62	6	39.	99309900	Screw M8 x 35	6		90265500	HP Seal 18mm	
17.	66210070	Plug 19mm	3	40.	96701400	Locking Washer M8	6	57.	47200074	Pump Rail	2
18.	90516500	Anti-ext ring	3	41.	97740500	Wrist Pin	3	58.	96710600	Washer M10	4
19.	66130141	Valve Cap	3	42.	66050066	Piston Guide	3	59.	99364400	Screw M10 x 18	4
20.	99306900	Screw M8 x 25	4	43.	96710100	Flinger Washer	3	60.	90912600	Guide Bushing	3
21.	66150274	Cover	1	44.	66040209	Plunger 16 x 54	3	61.	90162500	Seal, Pl. Rod 22 x 32 x 5.5	3
22.	44211801	Spacer, Sightglass	1	3				62.	96738000	Gasket, Aluminum 3/8"	1
23.	90409700	O-ring 55.56 x 3.53	1		66040309	Plunger 18 x 54	1	63.	96751400	Gasket, Aluminum 1/2"	1
								64.	98217600	Plug, G1/2" x 10	1

## REPAIR KITS

Kit No.	K02	K03	K15066	K174 (16mm)	K175 (16mm)	K180 (18mm)	K176 (18mm)
Pos. No.s Included In Kit	61	48	8, 9, 10, 11, 12, 11, 12, 13, 14, 16, 18 (7)	54, 56	52, 53, 54, 55, 56	54, 56	52, 53, 54, 55, 56
Number of Assemblies In Kit	3	1	6	3	1	3	1
Number of Cylinders Kit Will Service	3	N/A	3	3	1	3	1

## TORQUE SPECS\*

Item	N-M	Ft-lbs
3	45	33.2
19	130	95.9
20	20	14.8
34	10	7.4
37	20	14.8
39	20	14.8
46**	20	14.8
49	20	14.8
50	40	29.5
59	40	29.5

\*\* Use Loc-tite 542

\*Decrease torque by 20% if threads are lubricated.

**GENERAL PUMP 1174 Northland Drive • Mendota Heights, MN 55120**  
 Phone: 651.686.2199 • Fax: 800.535.1745 • e-mail: sales@gpcompanies.com • www.generalpump.com

Ref 310046 Rev. N  
04-19

