

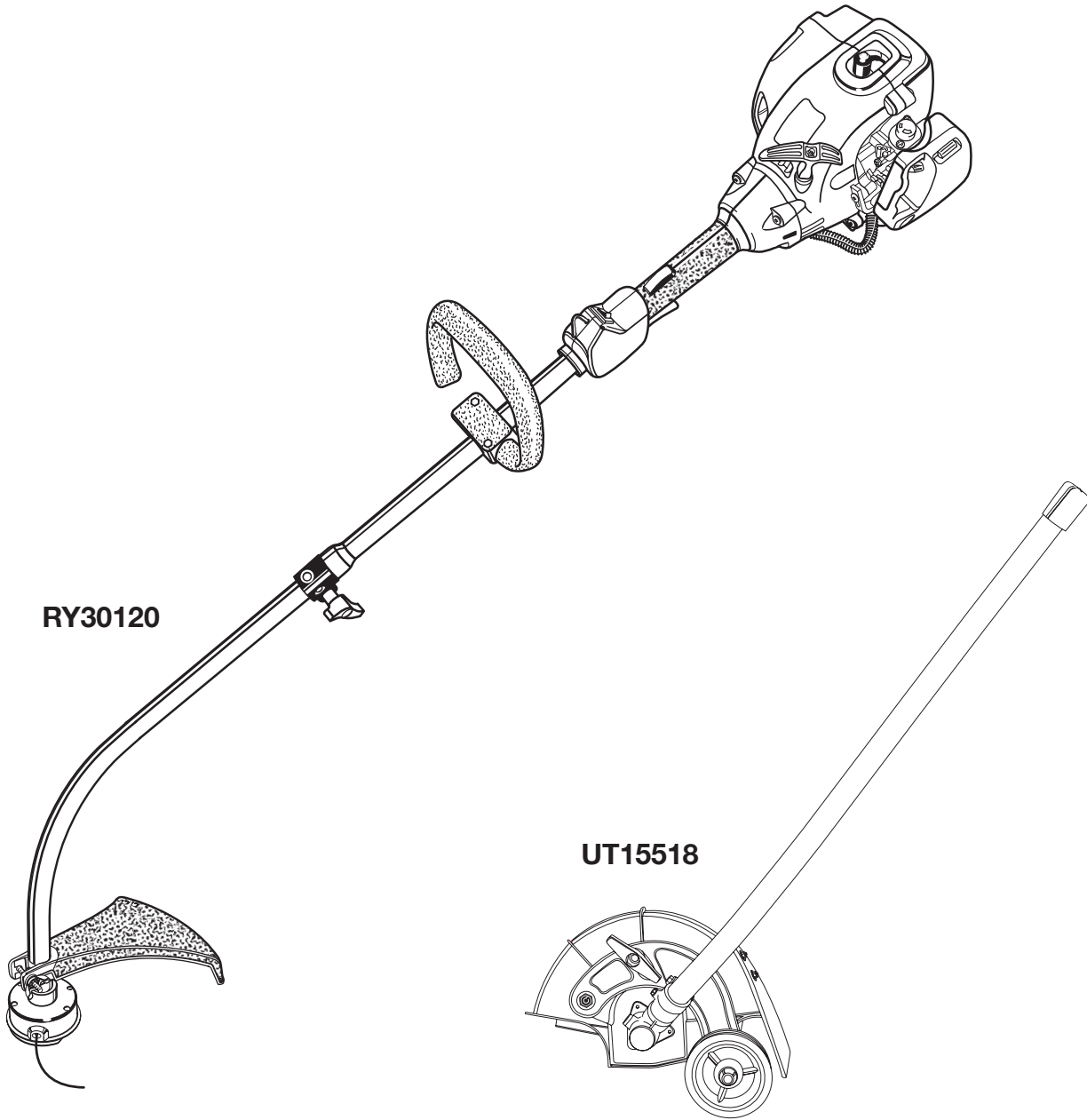

OPERATOR'S MANUAL

30CC STRING TRIMMER WITH EXPAND-IT™ EDGER ATTACHMENT

RY30130



Your new trimmer and edger attachment have been engineered and manufactured to our high standard for dependability, ease of operation, and operator safety. Properly cared for, they will give you years of rugged, trouble-free performance.



WARNING: To reduce the risk of injury, the user must read and understand the operator's manual before using this product.

Thank you for your purchase.

SAVE THIS MANUAL FOR FUTURE REFERENCE

TABLE OF CONTENTS

■ Introduction	2
■ General Safety Rules.....	3
■ Specific Safety Rules	4
■ Symbols	5 - 6
■ Features	7 - 8
■ Assembly.....	8 - 10
■ Operation.....	10 - 14
■ Maintenance	14 - 19
■ Troubleshooting.....	20 - 21
■ Warranty	21 - 23
■ Service Parts	Back Page

INTRODUCTION

This product has many features for making its use more pleasant and enjoyable. Safety, performance, and dependability have been given top priority in the design of this product making it easy to maintain and operate.

GENERAL SAFETY RULES

WARNING:

Read and understand all instructions. Failure to follow all instructions listed below may result in electric shock, fire and/or serious personal injury.

READ ALL INSTRUCTIONS

- For safe operation, read and understand all instructions before using this product. Follow all safety instructions. Failure to follow all safety instructions listed below can result in serious personal injury.
- Do not allow children or untrained individuals to use this unit.
- Never start or run the engine in a closed or poorly ventilated area; breathing exhaust fumes can kill.
- Clear the work area before each use. Remove all objects such as rocks, broken glass, nails, wire, or string which can be thrown or become entangled in the cutting line or blade.
- Wear safety glasses or goggles that are marked to comply with ANSI Z87.1 standards and hearing protection when operating this unit.
- Wear heavy, long pants, boots, and gloves. Do not wear loose fitting clothing, short pants, sandals, or go barefoot. Do not wear jewelry of any kind.
- Product users on United States Forest Service land, and in some states, must comply with fire prevention regulations. This product is equipped with a spark arrestor; however, other user requirements may apply. Check with your federal, state, or local authorities.
- Never operate this unit on the operator's left side.
- Secure long hair above shoulder level to prevent entanglement in moving parts.
- Keep all bystanders, children, and pets at least 50 ft. (15 m) away. Bystanders should be encouraged to wear eye protection.
- Do not operate this unit when you are tired, ill, or under the influence of alcohol, drugs, or medication.
- Do not operate in poor lighting.
- Keep firm footing and balance. Do not overreach. Overreaching can result in loss of balance or exposure to hot surfaces.
- Keep all parts of your body away from any moving part.
- To avoid hot surfaces, never operate the unit with the bottom of the engine above waist level.
- Do not touch area around the muffler or cylinder of the unit; these parts get hot from operation.
- Always stop the engine and remove the spark plug wire before making any adjustments or repairs except for carburetor adjustments. Wear your protective equipment and observe all safety instructions. When the unit is turned off, make sure the cutting attachment has stopped before setting the unit down.
- Inspect the unit before each use for loose fasteners, fuel leaks, etc. Replace any damaged parts before use.
- The string head or blade will rotate during carburetor adjustments.
- It has been reported that vibrations from hand-held tools may contribute to a condition called Raynaud's Syndrome in certain individuals. Symptoms may include tingling, numbness, and blanching of the fingers, usually apparent upon exposure to cold. Hereditary factors, exposure to cold and dampness, diet, smoking, and work practices are all thought to contribute to the development of these symptoms. It is presently unknown what, if any, vibrations or extent of exposure may contribute to the condition. There are measures that can be taken by the operator to possibly reduce the effects of vibration:
 - a) Keep your body warm in cold weather. When operating the unit wear gloves to keep hands and wrists warm. It is reported that cold weather is a major factor contributing to Raynaud's Syndrome.
 - b) After each period of operation, exercise to increase blood circulation.
 - c) Take frequent work breaks. Limit the amount of exposure per day.
 - d) Keep the tool well maintained, fasteners tightened, and worn parts replaced.If you experience any of the symptoms of this condition, immediately discontinue use and see your physician about these symptoms.
- Mix and store fuel in a container approved for gasoline.
- Mix fuel outdoors where there are no sparks or flames. Wipe up any fuel spillage. Move 30 ft. (9 m) away from refueling site before starting engine. Slowly remove the fuel cap after stopping engine. Do not smoke when refueling.
- Stop the engine and allow to cool before refueling or storing the unit.
- Allow the engine to cool; empty the fuel tank and secure the unit from moving before transporting in a vehicle.

SPECIFIC SAFETY RULES

SPECIFIC SAFETY RULES FOR TRIMMER USE

- Replace string head if cracked, chipped, or damaged in any way. Be sure the string head is properly installed and securely fastened. Failure to do so can cause serious injury.
- Make sure all guards, straps, deflectors, and handles are properly and securely attached.
- Use only the manufacturer's replacement string in the cutting head. Do not use any other cutting attachment. To install any other brand of cutting head to this string trimmer can result in serious personal injury.
- Never operate unit without the grass deflector in place and in good condition.
- Maintain a firm grip on both handles while trimming. Keep string head below waist level. Never cut with the string head located over 76 cm (30 in.) or more above the ground.

SPECIFIC SAFETY RULES FOR EDGER USE

- Clear the work area before each use. Remove all objects such as rocks, broken glass, nails, wire, or string which can be thrown or become entangled in the edger blade.
- Be sure all guards are properly and securely attached.
- Replace dull or worn blade; do not attempt to sharpen.
- Use this edger for edging along sidewalks, driveways, flower beds, and similar areas. Do not use for any other purpose.
- Be thoroughly familiar with the controls. Know how to stop the unit and disengage the controls quickly.
- Do not use edger in rain or wet locations.

- Do not use the edger on or near graveled surfaces.
- If the edger strikes any type of foreign object:
 - a) Stop the edger and remove the spark plug wire or disconnect from the power supply.
 - b) Inspect for damage to the edger attachment .
 - c) Correct damage before using the edger attachment. Failure to do so can cause serious injury.
- Make yourself familiar with the area you are edging. Be aware of uneven sidewalks and holes in the terrain as well as other similar hazardous conditions (example: wire or wire rope which can break off and become a dangerous projectile). Always push the edger attachment slowly over rough ground.
- Always stop the engine and remove the spark plug wire before attempting to remove any obstruction caught or jammed in the blade, installing attachment, or making any adjustments.
- Do not attempt to remove cut material nor hold material to be cut when the engine is running or when the cutting blade is moving.
- Keep hands and feet away from the cutting area.
- Always keep your right hand on the rear handle and your left hand on the front handle when the blade is rotating.











WARNING:

A coasting blade can cause injury while it continues to spin after the engine is stopped or throttle trigger released. Maintain proper control until the blade has completely stopped rotating.



SYMBOLS

Some of the following symbols may be used on this tool. Please study them and learn their meaning for safe operation of this product.

SYMBOL	NAME	EXPLANATION
	Safety Alert Symbol	Precautions that involve your safety.
	Read the Operator's Manual	To reduce the risk of injury, user must read and understand operator's manual before using this product.
	Wear Eye and Hearing Protection	Wear eye protection which is marked to comply with ANSI Z87.1 as well as hearing protection when operating this equipment.
	Keep Bystanders Away	Keep all bystanders at least 50 ft. (15 m) away.
	Ricochet	Thrown objects can ricochet and result in personal injury or property damage.
	Sharp Blade	Danger – Keep hands and feet away from rotating blade.
	No Blade	Do not install or use any type of blade on a product displaying this symbol.
	Gasoline and Oil	Use unleaded gasoline intended for motor vehicle use with an octane rating of 87 [(R + M) / 2] or higher. This product is powered by a 2-cycle engine and requires pre-mixing gasoline and 2-cycle oil.

SYMBOLS

The following signal words and meanings are intended to explain the levels of risk associated with this product.

SYMBOL	SIGNAL	MEANING
	DANGER:	Indicates an imminently hazardous situation, which, if not avoided, will result in death or serious injury.
	WARNING:	Indicates a potentially hazardous situation, which, if not avoided, could result in death or serious injury.
	CAUTION:	Indicates a potentially hazardous situation, which, if not avoided, may result in minor or moderate injury.
	CAUTION:	(Without Safety Alert Symbol) Indicates a situation that may result in property damage.

SERVICE

Servicing requires extreme care and knowledge and should be performed only by a qualified service technician. For service we suggest you return the product to your nearest **AUTHORIZED SERVICE CENTER** for repair. When servicing, use only identical replacement parts.



WARNING:

To avoid serious personal injury, do not attempt to use this product until you read thoroughly and understand completely the operator's manual. Save this operator's manual and review frequently for continuing safe operation and instructing others who may use this product.



WARNING:



The operation of any power tool can result in foreign objects being thrown into your eyes, which can result in severe eye damage. Before beginning power tool operation, always wear safety goggles or safety glasses with side shields and, when needed, a full face shield. We recommend Wide Vision Safety Mask for use over eyeglasses or standard safety glasses with side shields. Always use eye protection which is marked to comply with ANSI Z87.1.

SAVE THESE INSTRUCTIONS

FEATURES

PRODUCT SPECIFICATIONS

Weight (without fuel)	10.7 lbs. (4.9 kg.)
String Cutting Width17 in. (432 mm)
String Diameter080 in. (2.0 mm)
Engine Displacement30cc

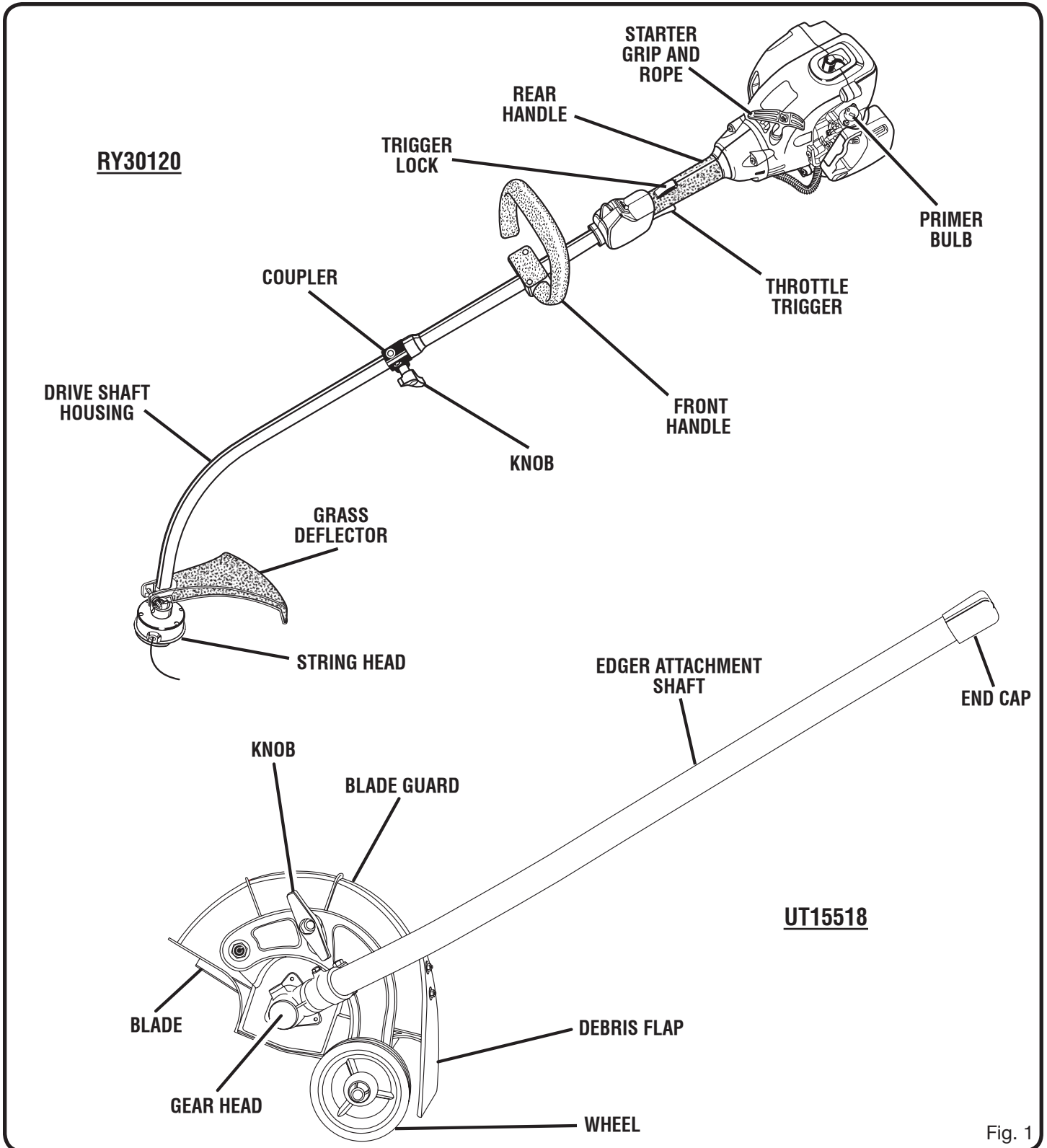

Fig. 1

FEATURES

KNOW YOUR STRING TRIMMER AND EDGER ATTACHMENT

See Figure 1.

Before attempting to use this product, familiarize yourself with all operating features and safety rules.

DEBRIS FLAP

The debris flap helps protect you from flying debris when using the edger attachment.

ERGONOMIC DESIGN

The design of both the trimmer and the edger attachment provides for easy handling. It is designed for comfort and

ease of grasp when operating in different positions and at different angles.

GRASS DEFLECTOR

The trimmer includes a grass deflector that helps protect you from flying debris.

TOP-MOUNTED MOTOR

The top-mounted motor improves balance and is located away from the dust and debris of the cutting area.

ASSEMBLY

UNPACKING

This product requires assembly.

- Carefully remove the tool and any accessories from the box. Make sure that all items listed in the packing list are included.
- Inspect the tool carefully to make sure no breakage or damage occurred during shipping.
- Do not discard the packing material until you have carefully inspected and satisfactorily operated the tool.
- If any parts are damaged or missing, please call 1-800-860-4050 for assistance.

PACKING LIST

Trimmer Assembly (RY30120)

Front Handle

Grass Deflector

Bottle of 2-Cycle Oil

Hanger Cap

Expand-It™ Edger Attachment (UT15518)

Holding Pin

Operator's Manual



WARNING:

If any parts are damaged or missing, do not operate this tool until the parts are replaced. Failure to heed this warning could result in serious personal injury.



WARNING:

Do not attempt to modify this tool or create accessories not recommended for use with this tool. Any such alteration or modification is misuse and could result in a hazardous condition leading to possible serious personal injury.



WARNING:

To prevent accidental starting that could cause serious personal injury, always disconnect the engine spark plug wire from the spark plug when assembling parts.

ASSEMBLY

INSTALLING AN ATTACHMENT TO THE POWER HEAD

See Figure 2.

⚠ WARNING:

Never install, remove, or adjust any attachment while power head is running. Failure to stop the engine can cause serious personal injury.

The attachments connect to the power head by means of a coupler device.

- Loosen the knob on the coupler of the power head shaft and remove the end cap from the attachment.
- Push in the button located on the attachment shaft. Align the button with the guide recess on the power head coupler and slide the two shafts together. Rotate the attachment shaft until the button locks into the positioning hole.

NOTE: If the button does not release completely in the positioning hole, the shafts are not locked into place. Slightly rotate from side to side until the button is locked into place.

- Tighten the knob securely.

⚠ WARNING:

Be certain the knob is fully tightened before operating equipment; check it periodically for tightness during use to avoid serious personal injury.

REMOVING AN ATTACHMENT FROM THE POWER HEAD

To remove or change the attachment:

- Loosen the knob.
- Push in the button and twist the shafts to remove and separate ends.

ATTACHING THE FRONT HANDLE TO THE POWER HEAD SHAFT

See Figure 3.

- Remove 2 wing nuts, 2 bolts, and clamp from the front handle.
- Install the front handle onto the top side of the drive shaft housing and move it to a comfortable position.
- Place the bolt through the front handle.

NOTE: The hex bolt head fits inside the hex recess molded into one side of the handle.

- Reinstall the clamp, bolts, and wing nuts.
- Tighten wing nut securely.

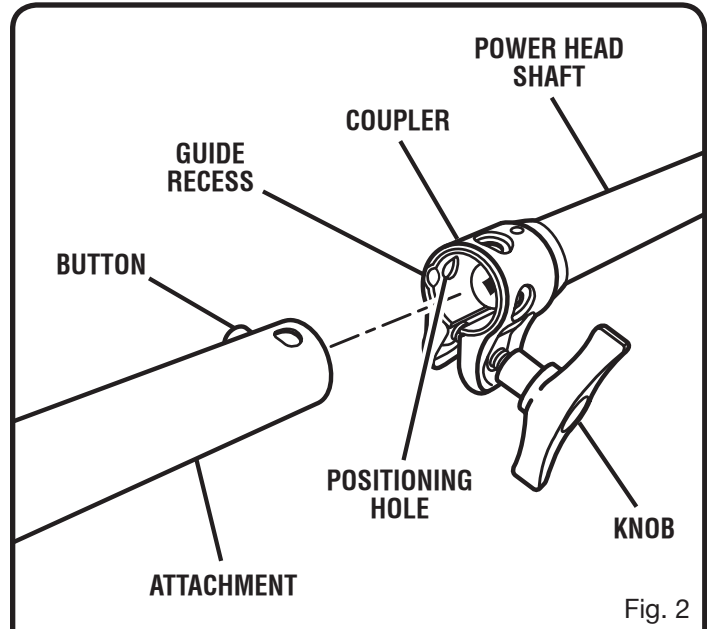

Fig. 2

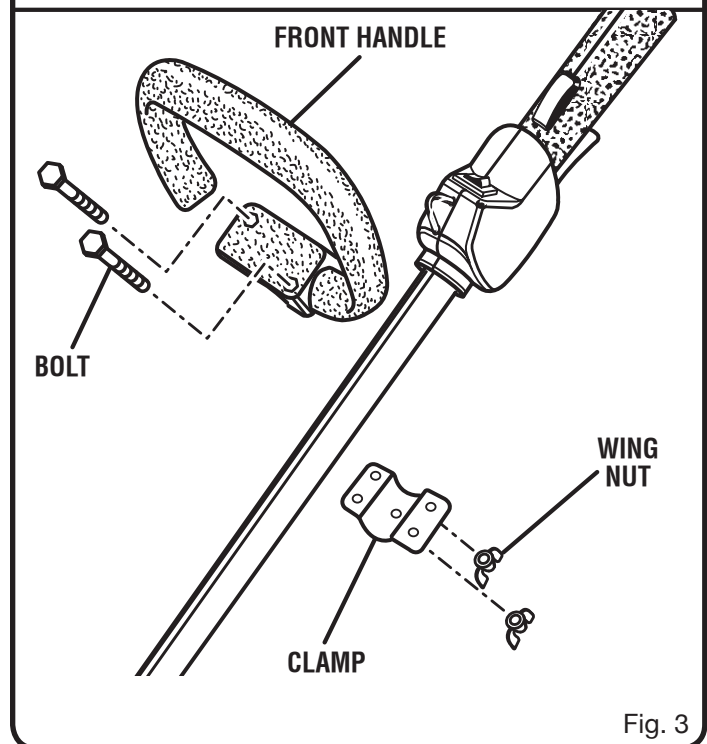

Fig. 3

ASSEMBLY

ATTACHING THE GRASS DEFLECTOR

See Figure 4.

WARNING:

The line cutting blade on the grass deflector is sharp. Avoid contact with the blade. Failure to avoid contact can result in serious personal injury.

- Remove the hex screw, flat washer, lock washer, and wing nut from the grass deflector.
- Press the grass deflector onto the bottom of the curved shaft as shown.
- Insert the hex screw through the grass deflector and the bracket on the curved shaft.
- Place the flat washer and lock washer on the hex head cap screw.
- Place the wing nut on the hex head cap screw and tighten securely.

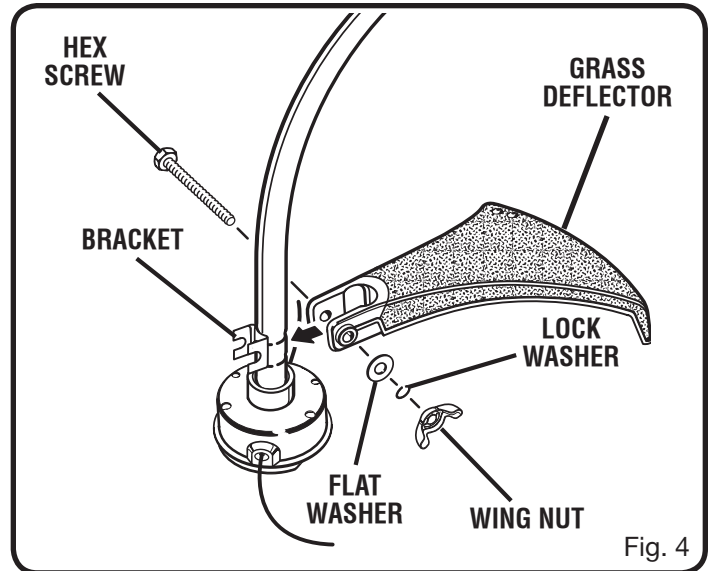

OPERATION

WARNING:

Do not allow familiarity with tools to make you careless. Remember that a careless fraction of a second is sufficient to inflict serious injury.

WARNING:

Always wear safety goggles or safety glasses with side shields when operating tools. Failure to do so could result in objects being thrown into your eyes, resulting in possible serious injury.

WARNING:

Do not use any attachments or accessories not recommended by the manufacturer of this tool. The use of attachments or accessories not recommended can result in serious personal injury.

FUELING AND REFUELING THE TRIMMER

FUEL MIXTURE

This product is powered by a 2-cycle engine and requires pre-mixing gasoline and 2-cycle oil. Pre-mix unleaded gasoline and 2-cycle engine oil in a clean 1 gallon container approved for gasoline.

Recommended fuel: This engine is certified to operate on unleaded gasoline intended for automotive use.

Mix a high quality 2-cycle engine oil at 2.6 oz. per gallon (US).

Do not use automotive oil or 2-cycle outboard oil. DO NOT mix quantities larger than usable in a 30 day period.



HIGH QUALITY 2-CYCLE ENGINE OIL

GASOLINE

1 gallon (US)

1 Liter

OIL

2.6 oz.

20 cc (20 ml)

FILLING TANK

- Clean surface around fuel cap to prevent contamination.
- Loosen fuel cap slowly. Rest cap on a clean surface.
- Carefully pour fuel into the tank. Avoid spillage.
- Prior to replacing the fuel cap, clean and inspect the gasket.
- Immediately replace fuel cap and hand tighten. Wipe up any fuel spillage.

NOTE: It is normal for smoke to be emitted from a new engine after first use.

WARNING:

Always shut off engine before fueling. Never add fuel to a machine with a running or hot engine. Move at least 30 ft. (9 m) from refueling site before starting engine. Do not smoke!

OPERATION

STARTING AND STOPPING

See Figures 5 - 7.

TO START A COLD ENGINE:

DO NOT squeeze the throttle trigger until the engine starts and runs.

- Lay the trimmer on a flat, bare surface.
- **PRIME** - Press the primer bulb 7 times.
- **SET** the start lever to the **START** position.
- **PULL** the rope until the engine starts.
- Wait 6-10 seconds, then squeeze the trigger to run.

NOTE: Squeezing the throttle trigger releases the start lever to the **RUN** position.

TO START A WARM ENGINE:

PULL the rope until the engine starts.

TO STOP THE ENGINE:

Press and hold the switch in the stop “” position until the engine stops.

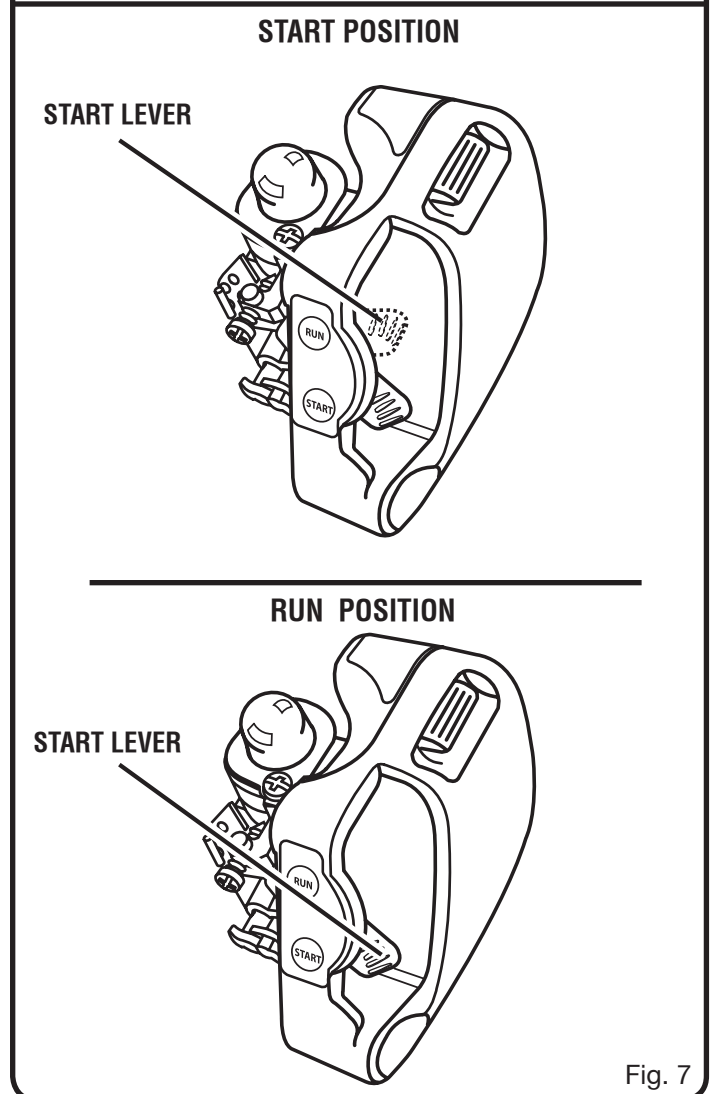
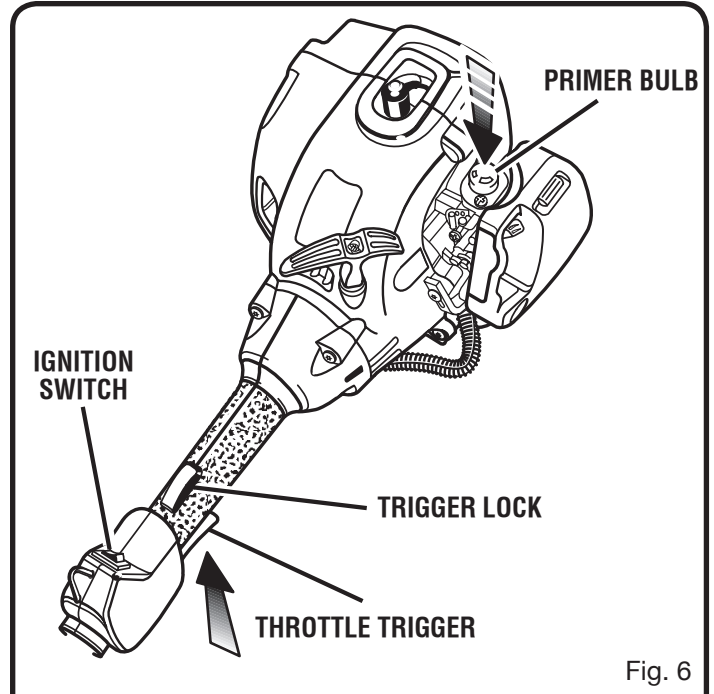
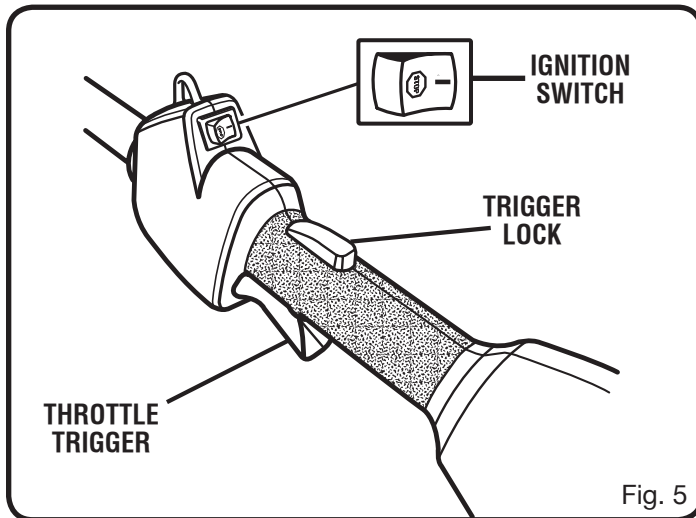

OPERATION

ADVANCING TRIMMER CUTTING LINE

String advance is controlled by tapping the string head on grass while running engine at full throttle.

- Run engine at full throttle.
- Tap the spool retainer on ground to advance string. The string advances each time the spool retainer is tapped. Do not hold the spool retainer on the ground.

NOTE: The line trimming cut-off blade on the grass deflector will cut the line to the correct length.

- If the string is worn too short you may not be able to advance the string by tapping it on the ground. If so, stop the engine and manually advance the string by pushing the spool retainer down while pulling on string(s).

GRASS DEFLECTOR LINE TRIMMING CUT-OFF BLADE

See Figure 8.

The trimmer is equipped with a line trimming cut-off blade on the grass deflector. For best cutting, advance string until it is trimmed to length by the cut-off blade. Advance the string whenever you hear the engine running faster than normal, or when trimming efficiency diminishes. This will maintain best performance and keep the string long enough to advance properly.

OPERATING THE TRIMMER

See Figure 9.

WARNING:

Always position the unit on the operator's right side. The use of the unit on the operator's left side will expose the user to hot surfaces and can result in possible burn injury.

WARNING:

To avoid burns from hot surfaces, never operate unit with the bottom of the engine above waist level.

Hold the trimmer with your right hand on the rear handle and your left hand on the front handle. Keep a firm grip with both hands while in operation. Trimmer should be held at a comfortable position with the rear handle about hip height.

Always operate trimmer at full throttle. Cut tall grass from the top down. This will prevent grass from wrapping around the shaft housing and string head which could cause damage from overheating. If grass becomes wrapped around the string head, STOP THE ENGINE, disconnect the spark plug wire, and remove the grass. Prolonged cutting at partial throttle will result in oil dripping from the muffler.



Fig. 8

PROPER OPERATING POSITION



Fig. 9

DANGEROUS CUTTING AREA

DIRECTION OF ROTATION

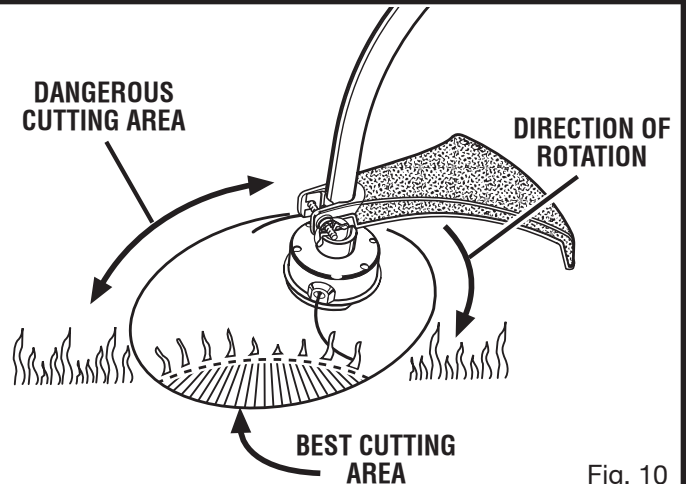

Fig. 10

OPERATION

WARNING:

Always hold the string trimmer away from the body keeping clearance between the body and the product. Any contact with the housing or string trimmer cutting head can result in burns and/or other serious personal injury.

TRIMMER CUTTING TIPS

See Figures 9 -10.

- Avoid hot surfaces by always keeping the tool away from your body. (Proper operating position shown in figure 9.)
- Keep the trimmer tilted toward the area being cut; this is the best cutting area.
- The trimmer cuts when passing the unit from right to left. This will avoid throwing debris at the operator. Avoid cutting in the dangerous area shown in figure 10.
- Use the tip of string to do the cutting; do not force string head into uncut grass.
- Wire and picket fences cause extra string wear and breakage. Stone and brick walls, curbs, and wood may wear string rapidly.
- Avoid trees and shrubs. Tree bark, wood moldings, siding, and fence posts can easily be damaged by the string.

OPERATING THE EDGER

See Figure 11.

Hold the edger with your right hand on the rear handle and your left hand on the front handle. The edger should be held on the right side of the body. Keep a firm grip with both hands while in operation. The edger should be held at a comfortable position with the rear handle about hip height.

NOTE: When the attachment is being used on a trimmer with a gasoline engine, always operate at full throttle. Prolonged cutting at partial throttle will result in oil dripping from the muffler.

EDGER CUTTING TIPS

See Figure 11.

- The edger will edge along sidewalks, driveways, flower beds, curbs, and similar areas.
- Use the arrow guide on the blade guard to align the blade with the edging surface.
- Cut at a steady pace. If the blade begins to bog down, you are edging too fast; slow your pace. Do not force the blade into ground.
- Light contact of the blade against the sidewalk edge, curb, etc., is acceptable and will not damage the edger.
- Best appearance is obtained when grass is dry. Avoid edging in wet soil or wet grass areas or the blade guard might clog and result in an uneven edge. If the blade guard becomes clogged, stop the engine, remove the spark plug wire or disconnect from the power supply, and remove debris from the blade guard.

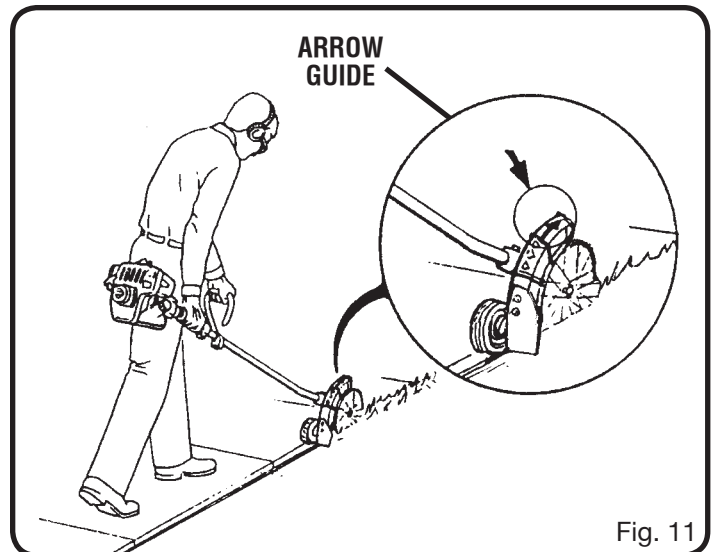

Fig. 11

OPERATION

ADJUSTING EDGER BLADE DEPTH

See Figures 12 - 13.

Depth of the cut is determined by the distance from the bottom of the wheel to the tip of blade.

- Stop the engine and remove the spark plug wire or disconnect from the power source.
- Loosen the adjusting knob and move the wheel arm up to increase the depth and down to decrease the depth.
- After adjustment is complete, tighten the adjusting knob securely.
- Replace the spark plug wire or connect to the power supply and start the unit.

NOTE: Adjust the blade depth from 1/2 in. to 1 in. (1.2 to 2.5 cm) deep initially. Make a shallow cut to test the cutting depth. If the cutting depth needs adjusting, this should be done progressively until the desired depth is reached.

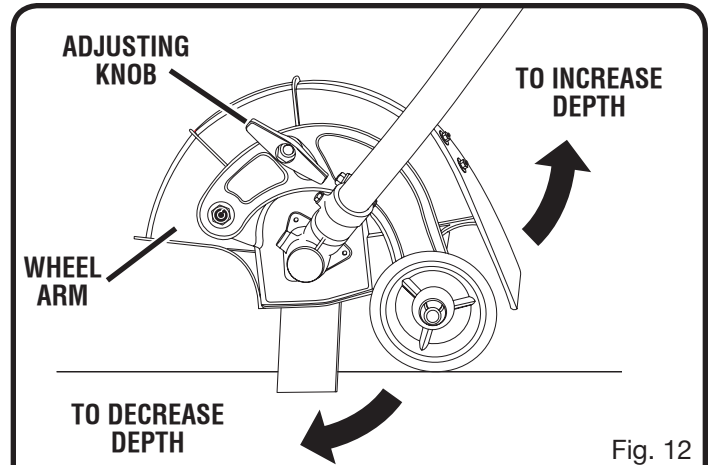

Fig. 12

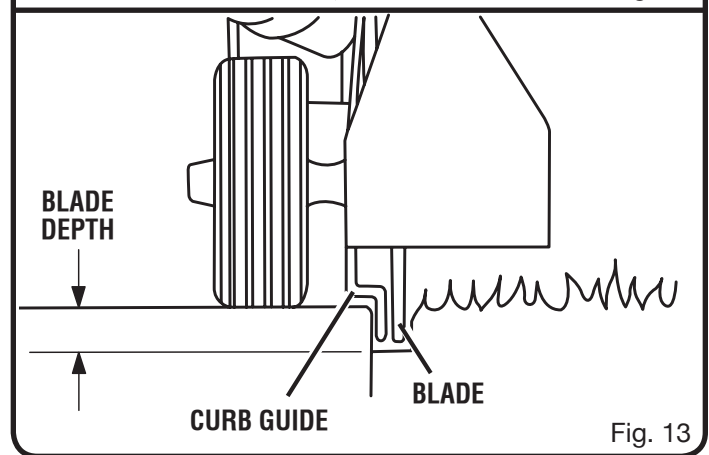

Fig. 13

MAINTENANCE

⚠ WARNING:

When servicing, use only identical replacement parts. Use of any other parts may create a hazard or cause product damage.

⚠ WARNING:

Always wear safety goggles or safety glasses with side shields during tool operation. If operation is dusty, also wear a dust mask.

⚠ WARNING:

Before inspecting, cleaning, or servicing the machine, shut off engine, wait for all moving parts to stop, and disconnect spark plug wire and move it away from spark plug. Failure to follow these instructions can result in serious personal injury or property damage.

GENERAL MAINTENANCE

Avoid using solvents when cleaning plastic parts. Most plastics are susceptible to damage from various types of commercial solvents and may be damaged by their use. Use clean cloths to remove dirt, dust, oil, grease, etc.

⚠ WARNING:

Do not at any time let brake fluids, gasoline, petroleum-based products, penetrating oils, etc., come in contact with plastic parts. Chemicals can damage, weaken or destroy plastic which may result in serious personal injury.

You can often make adjustments and repairs described here. For other repairs, have the trimmer serviced by an authorized service dealer.

MAINTENANCE

SPOOL REPLACEMENT (NEW PREWOUND SPOOL)

See Figures 14 - 15.

If replacing string only, refer to **String Replacement** later in this manual.

Use only monofilament string. For best performance, use original manufacturer's replacement string.

String Diameter: .080 in. (2.0 mm)

- Stop the engine and disconnect the spark plug wire. Hold the string head and unscrew the spool retainer.
- Turn the spool retainer counterclockwise.
- Remove the empty spool from the string head. Keep the spring attached to the spool.
- To install the new spool, make sure the two strings are captured in the slots opposite each other on the new spool. Make sure the ends of each string are extended approximately 6 in. (152 mm) beyond each slot.
- Thread the strings into the eyelets in the string head. Carefully push the spool into the string head (gently pull the strings to the outside if necessary). When the spool is positioned in the string head, grasp the strings and pull sharply to release them from the slots in the spool.
- Push down and turn the spool counterclockwise until it no longer turns. Hold the spool down and rotate clockwise a small amount. Release the spool. The spool should be locked down in the string head. If not, hold down and rotate until locked.
- Make sure the string head and the spool retainer are installed on the drive shaft.
- Turn the spool retainer clockwise.
- Pull the strings again to rotate the spool into cutting position. Push the spool retainer down while pulling on string(s) to manually advance the string and to check for proper assembly of the string head.

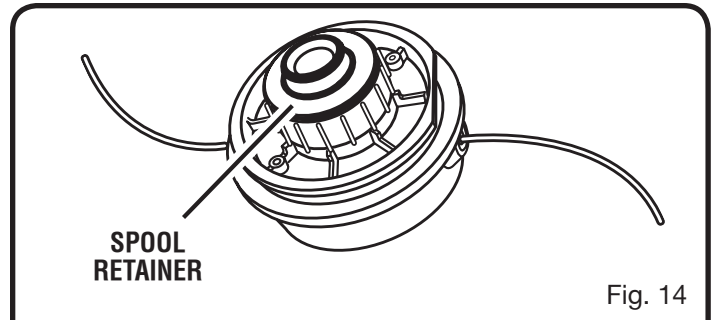

Fig. 14

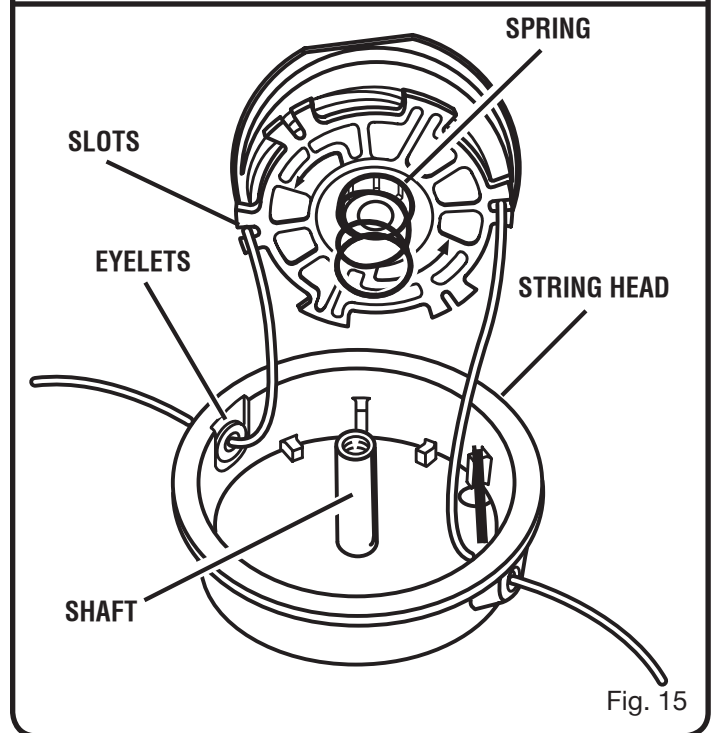

Fig. 15

MAINTENANCE

STRING REPLACEMENT

See Figures 16 - 18.

Use only monofilament string. For best performance, use original manufacturer's replacement string.

String Diameter: .080 in. (2.0 mm)

- Stop the engine; disconnect the spark plug wire. Hold the string head and unscrew the spool retainer.
- Turn the spool retainer counterclockwise.
- Remove the spool from the string head.

NOTE: Keep the spring attached to the spool. Remove any old string remaining on the spool.

- Cut two pieces of string, each being approximately 9 ft. (2.7 m) long.
- Insert the first string into the anchor hole in the upper part of the spool. Wind the first string around the upper part of the spool counterclockwise, as shown by the arrows on the spool. Place string in the slot on upper spool flange, leaving about 6 in. (152 mm) extended beyond the slot. Do not overfill. After winding the string, there should be at least 1/4 in. (6 mm) between the wound string and the outside edge of the spool.
- Repeat above step with second string, using the bottom part of spool. Do not overfill.
- Replace the spool and the spool retainer. Refer to **Spool Replacement** earlier in this manual.

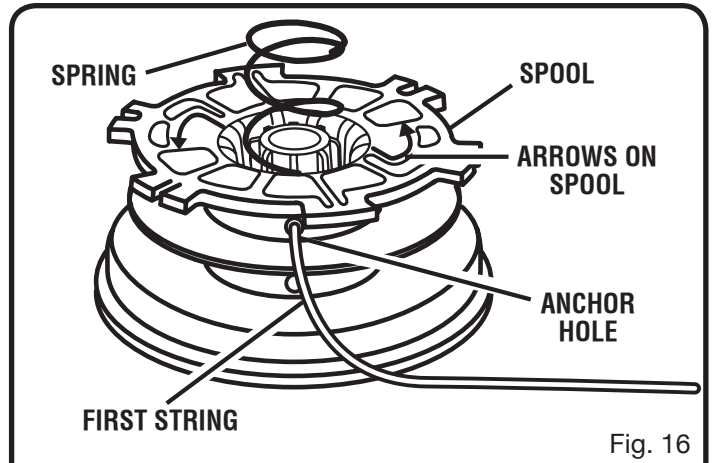

Fig. 16

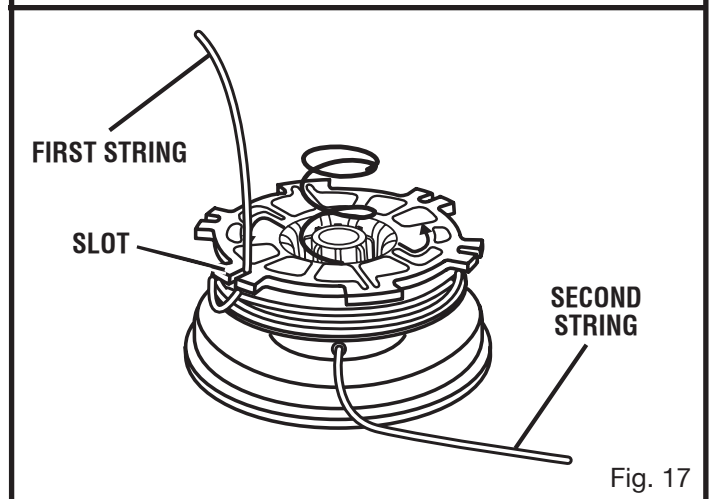

Fig. 17

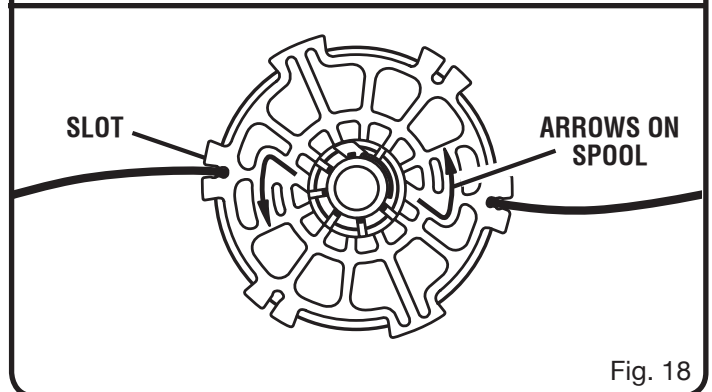

Fig. 18

MAINTENANCE

CLEANING THE EXHAUST PORT AND MUFFLER

Depending on the type of fuel used, the type and amount of oil used, and/or your operating conditions, the exhaust port, muffler, and/or spark arrestor screen may become blocked with carbon deposits. If you notice a power loss with your gas powered tool, you may need to remove these deposits to restore performance. We highly recommend that only qualified service technicians perform this service.

SPARK ARRESTOR

The spark arrestor must be cleaned or replaced every 25 hours or yearly to ensure proper performance of your product. Spark arrestors may be in different locations depending on the model purchased. Please contact your nearest service dealer for the location of the spark arrestor for your model.

REPLACING AND CLEANING AIR FILTER

See Figures 19 - 20.

For proper performance and long life, keep air filter clean. For best performance, replace annually.

- Remove the air filter cover by pushing down on the latch with your thumb while gently pulling on the cover.
- Remove the air filter and clean it in warm soapy water. Rinse and let dry completely.
- Reinstall the air filter.
- Replace the air filter cover by inserting the tabs on the bottom of the cover into the slots on the air filter base; push the cover up until it latches securely in place.

FUEL CAP

WARNING:

A leaking fuel cap is a fire hazard and must be replaced immediately.

The fuel cap contains a non-serviceable filter and a check valve. A clogged fuel filter will cause poor engine performance. If performance improves when the fuel cap is loosened, check valve may be faulty or filter clogged. Replace fuel cap if required.

SPARK PLUG REPLACEMENT

This engine uses a Champion RCJ-6Y or NGK BPMR7A spark plug with .025 in. (0.63 mm) electrode gap. Use an exact replacement and replace annually.

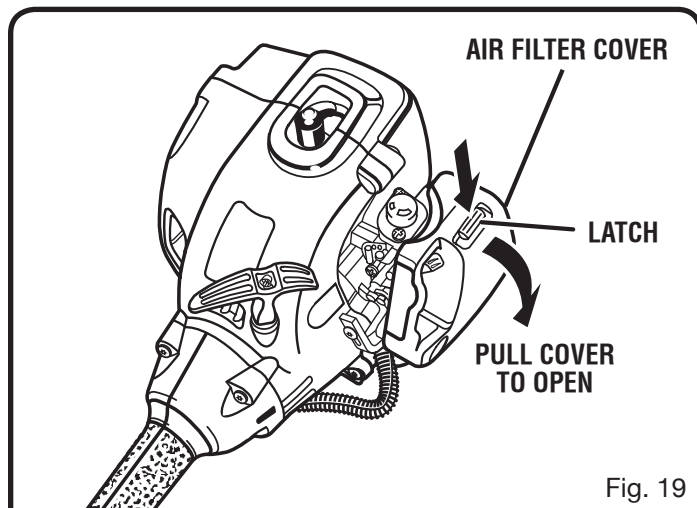

Fig. 19

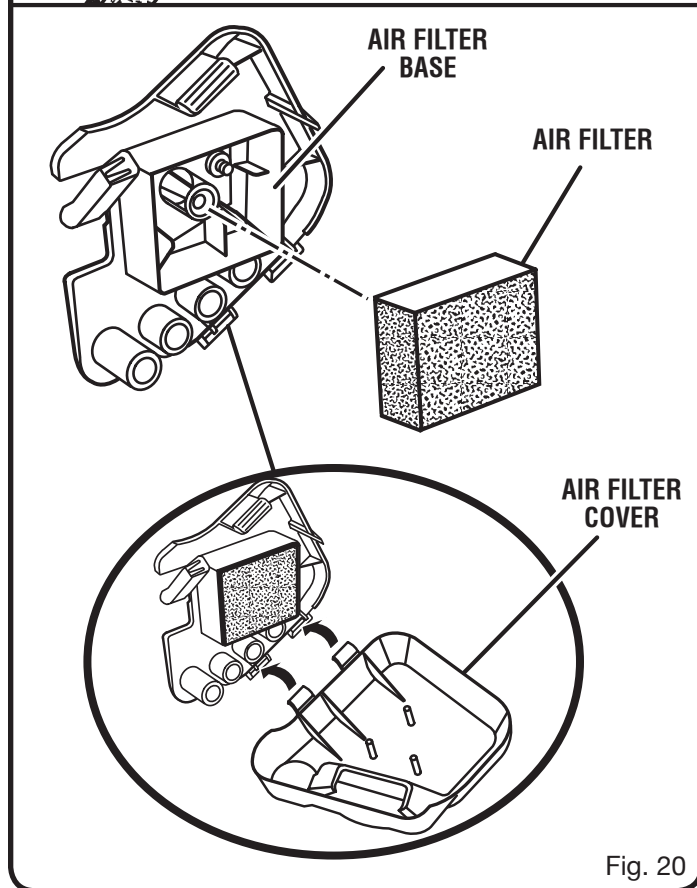

Fig. 20

MAINTENANCE

EDGER BLADE REPLACEMENT

See Figures 21 - 24.

Replace blades that are damaged or worn.

Stop the engine and remove the spark plug wire or disconnect from the power supply.

Always make sure the blade is correctly installed and securely fastened before each use.

- Align the slot in the upper flange washer and gear case with the slot in the flange; place the holding pin through all three slots to secure in place.
- Using a 1/2 in. socket wrench, turn the blade nut clockwise to loosen.
- Remove the blade from the edger shaft.
- Clean debris from the edger shaft and flange washers.
- Center the blade on the upper flange washer making sure the blade sits flat.
- Install the lower flange washer with the cupped hole away from the blade.
- Install the blade nut onto the edger shaft.
- Align the slot in the upper flange washer and gear case with the slot in the flange; place the holding pin through all three slots to secure in place.
- Using a 1/2 in. socket wrench, turn the blade nut counterclockwise onto the edger shaft and tighten securely.

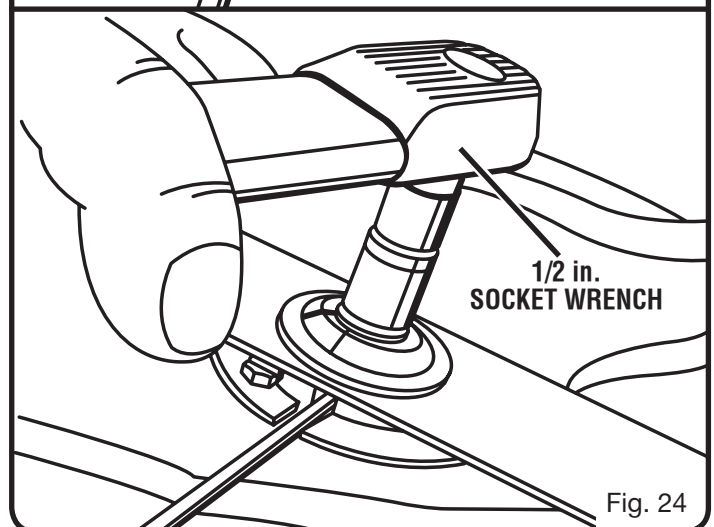
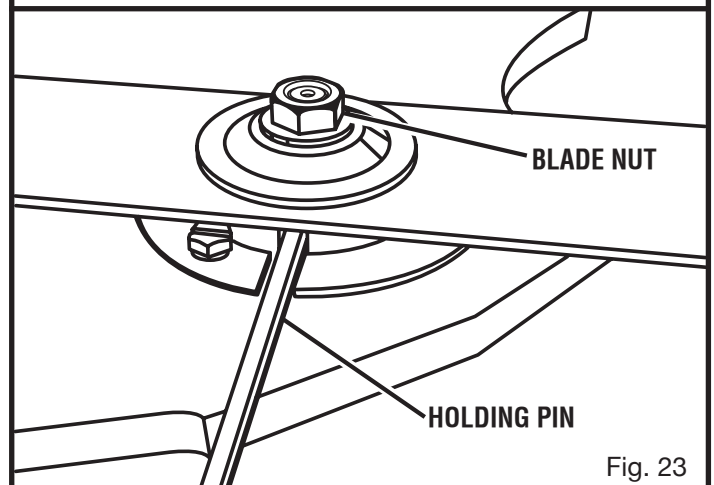
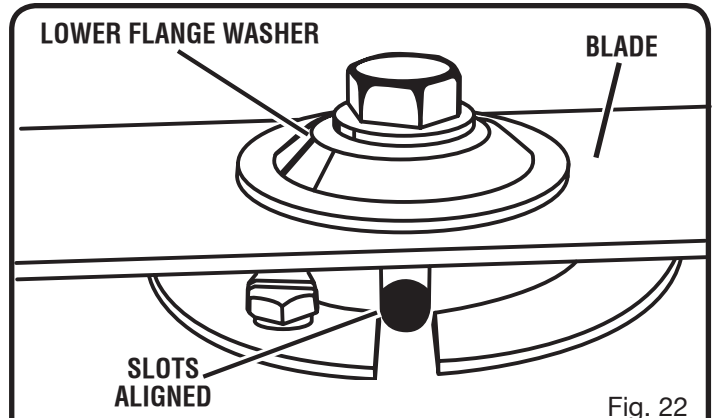
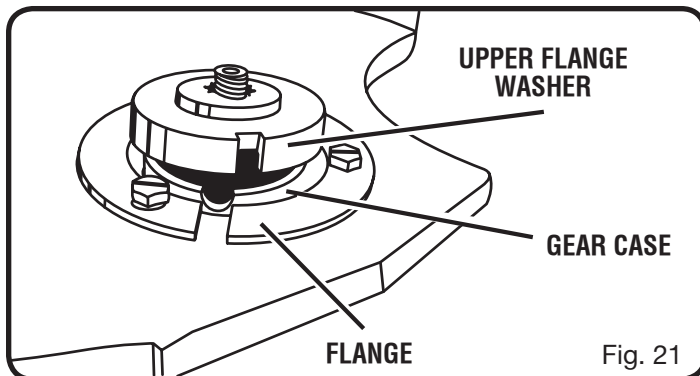

MAINTENANCE

DEBRIS FLAP REPLACEMENT

See Figure 25.

Replace the debris flap if it is worn.

- Using a 10 mm wrench or socket, remove the retaining nuts, washers, and debris flap.
- Install the new debris flap. This replacement part is available from the place of purchase, or by calling 1-800-242-4672.
- Replace retaining nuts and washers.
- Tighten securely.

STORAGE (1 MONTH OR LONGER)

- Drain all fuel from tank into a container approved for gasoline. Run engine until it stops.
- Abide by all ISO and local regulations for the safe storage and handling of gasoline. Excess fuel should be used up in other 2-cycle engine powered equipment.
- Clean all foreign material from attachments. Do not grasp exposed cutting blades when picking up or holding the attachments.
- Store idle unit indoors in a dry, well-ventilated area that is inaccessible to children. Keep away from corrosive agents such as garden chemicals and de-icing salts.

ATTACHING THE STORAGE HANGER

See Figure 26.

There are two ways to hang the attachment for storage.

- To use the hanger cap, push in the button and place the hanger cap over end of the lower end of attachment shaft. Slightly rotate the cap from side to side until the button locks into place.
- The secondary hole in the attachment shaft can be used for hanging purposes as well.

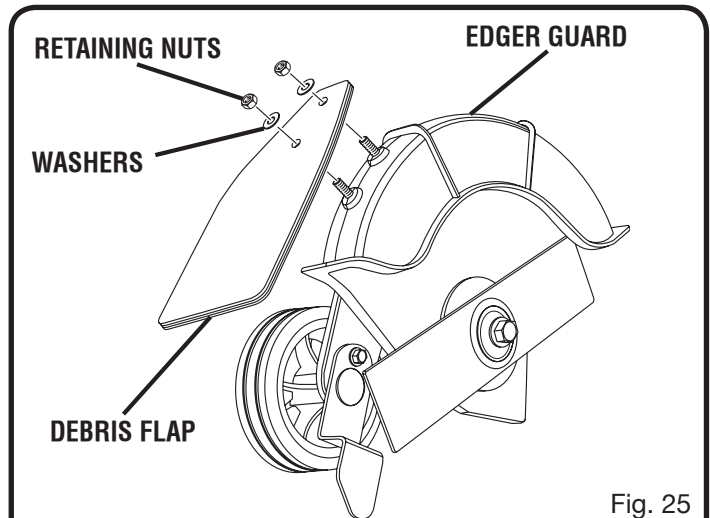

Fig. 25

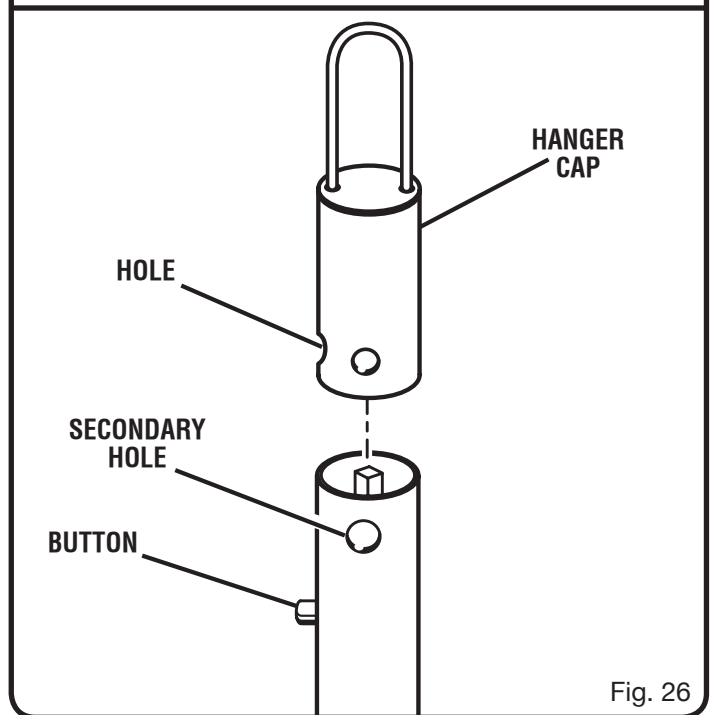

Fig. 26

TROUBLESHOOTING

IF THESE SOLUTIONS DO NOT SOLVE THE PROBLEM, CONTACT YOUR AUTHORIZED SERVICE DEALER.

PROBLEM	POSSIBLE CAUSE	SOLUTION
Engine will not start	<ol style="list-style-type: none"> 1. No spark. 2. No fuel. 3. Engine is flooded. 	<ol style="list-style-type: none"> 1. Check spark. Remove spark plug. Reattach the spark plug cap and lay spark plug on metal cylinder. Pull the rope and watch for spark at spark plug tip. If there is no spark, repeat test with a new spark plug. 2. Push primer bulb until bulb is full of fuel. If bulb does not fill, primary fuel delivery system is blocked. Contact a service dealer. If primer bulb fills, engine may be flooded; proceed to next item. 3. Set the start lever to the START position. Squeeze the trigger and pull the rope repeatedly until the engine starts and runs. NOTE: Depending on the severity of the flooding, this may require numerous pulls of the rope. See Starting and Stopping earlier in this manual.
Engine does not reach full speed and emits excessive smoke	<ol style="list-style-type: none"> 1. Incorrect oil/fuel mixture. 2. Air filter is dirty. 3. Spark arrestor screen is dirty. 4. Spark plug fouled. 	<ol style="list-style-type: none"> 1. Use fresh fuel and the correct 2-cycle oil mix. (50:1). 2. Clean air filter. Refer to Replacing and Cleaning Air Filter earlier in this manual. 3. Contact a servicing dealer. 4. Clean or replace spark plug. Reset spark plug gap. Refer to Spark Plug Replacement earlier in this manual.
Engine starts, runs, and accelerates but will not idle	<ol style="list-style-type: none"> 1. Idle speed screw on carburetor needs adjustment. 	<ol style="list-style-type: none"> 1. Turn idle speed screw clockwise to increase idle speed. <i>See Figure 27.</i>
String will not advance	<ol style="list-style-type: none"> 1. String is welded to itself. 2. Not enough string on spool. 3. String is worn too short. 4. String is tangled on spool. 5. Engine speed is too slow. 	<ol style="list-style-type: none"> 1. Lubricate string with silicone spray. 2. Install more string. Refer to String Replacement earlier in this manual. 3. Pull strings while alternately pressing down on and releasing spool retainer. 4. Remove string from spool and rewind. Refer to String Replacement earlier in this manual. 5. Advance string at full throttle.

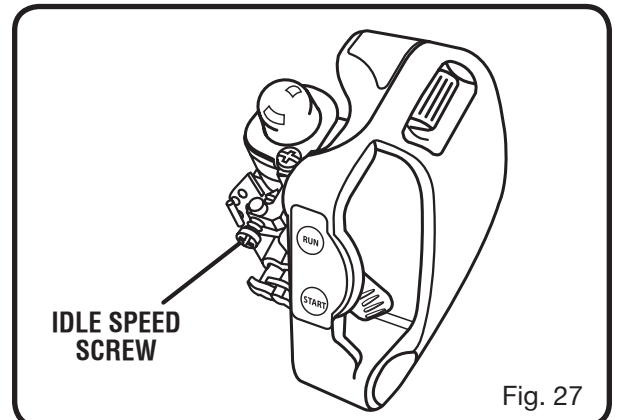

Fig. 27

TROUBLESHOOTING

IF THESE SOLUTIONS DO NOT SOLVE THE PROBLEM, CONTACT YOUR AUTHORIZED SERVICE DEALER.

PROBLEM	POSSIBLE CAUSE	SOLUTION
Spool retainer hard to turn	1. Screw threads are dirty or damaged.	1. Clean threads and lubricate with grease - if no improvement, replace the spool retainer.
Grass wraps around driveshaft housing and string head	1. Cutting tall grass at ground level. 2. Operating trimmer at part throttle.	1. Cut tall grass from the top down to prevent wrapping. 2. Operate trimmer at full throttle.

WARRANTY

THIS PRODUCT WAS MANUFACTURED WITH A CATALYST MUFFLER

Congratulations! You have made an investment toward protecting the environment. In order to maintain this product's original emission level, please refer to the maintenance section below.

EMISSIONS MAINTENANCE SCHEDULE AND WARRANTED PARTS LIST

Emissions Parts	Inspect Before Each Use	Clean Every 5 Hours	Replace Every 25 Hours or Yearly	Clean Every 25 Hours or Yearly	Replace Every 50 Hours
CATALYTIC MUFFLER ASSEMBLY					X
AIR FILTER ASSY					
includes:					
Filter		X	X		
SPARK SCREEN					X
CARBURETOR ASSY					
includes:					
Heat Dam					
Gaskets					
FUEL TANK ASSY					
includes:					
Fuel Lines			X		
Fuel Cap			X		
Fuel Filter					
IGNITION ASSY					
includes:					
Spark Plug			X		

ALL EMISSIONS RELATED PARTS ARE WARRANTED FOR TWO YEARS OR FOR THE PERIOD OF TIME PRIOR TO THE PARTS FIRST SCHEDULED REPLACEMENT WHICHEVER COMES FIRST.



CALL US FIRST

For any questions about operating or maintaining your product,
call the Ryobi® Help Line!

Your product has been fully tested prior to shipment to ensure
your complete satisfaction.

WARRANTY

LIMITED WARRANTY STATEMENT

Techtronic Industries North America, Inc., warrants to the original retail purchaser that this RYOBI® brand outdoor product is free from defect in material and workmanship and agrees to repair or replace, at Techtronic Industries North America, Inc.'s, discretion, any defective product free of charge within these time periods from the date of purchase.

- Two years if the product is used for personal, family or household use;
- 90 days, if used for any other purpose, such as commercial or rental.

This warranty extends to the original retail purchaser only and commences on the date of the original retail purchase.

Any part of this product found in the reasonable judgment of Techtronic Industries North America, Inc. to be defective in material or workmanship will be repaired or replaced without charge for parts and labor by an authorized service center for RYOBI® brand outdoor products (Authorized Ryobi Service Center).

The product, including any defective part, must be returned to an authorized RYOBI service center within the warranty period. The expense of delivering the product to the service center for warranty work and the expense of returning it back to the owner after repair or replacement will be paid by the owner. Techtronic Industries North America, Inc.'s, responsibility in respect to claims is limited to making the required repairs or replacements and no claim of breach of warranty shall be cause for cancellation or rescission of the contract of sale of any RYOBI® brand outdoor product. Proof of purchase will be required by the dealer to substantiate any warranty claim. All warranty work must be performed by an authorized service dealer.

This warranty is limited to ninety (90) days from the date of original retail purchase for any RYOBI® brand outdoor product that is used for rental or commercial purposes, or any other income-producing purpose.

This warranty does not cover any product that has been subject to misuse, neglect, negligence, or accident, or that has been operated in any way contrary to the operating instructions as specified in this operator's manual. This warranty does not apply to any damage to the product that is the result of improper maintenance or to any product that has been altered or modified. The warranty does not extend to repairs made necessary by normal wear or by the use of parts or accessories which are either incompatible with the RYOBI® brand outdoor product or adversely affect its operation, performance, or durability.

In addition, this warranty does not cover:

- A. Tune-ups – Spark Plugs, Carburetor, Carburetor Adjustments, Ignition, Filters
- B. Wear items – Bump Knobs, Outer Spools, Cutting Lines, Inner Reels, Starter Pulleys, Starter Ropes, Drive Belts, Tines, Felt Washers, Hitch Pins, Mulching Blades, Blower Fans, Blower and Vacuum Tubes, Vacuum Bag and Straps, Guide Bars, Saw Chains

Techtronic Industries North America, Inc., reserves the right to change or improve the design of any RYOBI® brand outdoor product without assuming any obligation to modify any product previously manufactured.

ALL IMPLIED WARRANTIES ARE LIMITED IN DURATION TO THE STATED WARRANTY PERIOD. ACCORDINGLY, ANY SUCH IMPLIED WARRANTIES INCLUDING MERCHANTABILITY, FITNESS FOR A PARTICULAR PURPOSE, OR OTHERWISE, ARE DISCLAIMED IN THEIR ENTIRETY AFTER THE EXPIRATION OF THE APPROPRIATE TWO-YEAR, ONE-YEAR, OR NINETY-DAY WARRANTY PERIOD. TECHTRONIC INDUSTRIES NORTH AMERICA, INC.'S, OBLIGATION UNDER THIS WARRANTY IS STRICTLY AND EXCLUSIVELY LIMITED TO THE REPAIR OR REPLACEMENT OF DEFECTIVE PARTS AND TECHTRONIC INDUSTRIES NORTH AMERICA, INC., DOES NOT ASSUME OR AUTHORIZE ANYONE TO ASSUME FOR THEM ANY OTHER OBLIGATION. SOME STATES DO NOT ALLOW LIMITATIONS ON HOW LONG AN IMPLIED WARRANTY LASTS, SO THE ABOVE LIMITATION MAY NOT APPLY TO YOU. TECHTRONIC INDUSTRIES NORTH AMERICA, INC., ASSUMES NO RESPONSIBILITY FOR INCIDENTAL, CONSEQUENTIAL, OR OTHER DAMAGES INCLUDING, BUT NOT LIMITED TO, EXPENSE OF RETURNING THE PRODUCT TO AN AUTHORIZED RYOBI SERVICE CENTER AND EXPENSE OF DELIVERING IT BACK TO THE OWNER, MECHANIC'S TRAVEL TIME, TELEPHONE OR TELEGRAM CHARGES, RENTAL OF A LIKE PRODUCT DURING THE TIME WARRANTY SERVICE IS BEING PERFORMED, TRAVEL, LOSS OR DAMAGE TO PERSONAL PROPERTY, LOSS OF REVENUE, LOSS OF USE OF THE PRODUCT, LOSS OF TIME, OR INCONVENIENCE. SOME STATES DO NOT ALLOW THE EXCLUSION OR LIMITATION OF INCIDENTAL OR CONSEQUENTIAL DAMAGES, SO THE ABOVE LIMITATION OR EXCLUSION MAY NOT APPLY TO YOU.

This warranty gives you specific legal rights, and you may also have other rights which vary from state to state.

This warranty applies to all RYOBI® brand outdoor products manufactured by or for Techtronic Industries North America, Inc., and sold in the United States and Canada.

To locate your nearest Authorized Ryobi Service Center, dial 1-800-860-4050.

WARRANTY

THE FOLLOWING CALIFORNIA AIR RESOURCES BOARD (CARB) STATEMENT ONLY APPLIES TO MODEL NUMBERS REQUIRED TO MEET THE CARB REQUIREMENTS.

TECHTRONIC INDUSTRIES NORTH AMERICA, INC., LIMITED WARRANTY FEDERAL AND CALIFORNIA EMISSION CONTROL SYSTEMS NON-ROAD AND SMALL OFF-ROAD ENGINES

The U.S. Environmental Protection Agency (EPA), the California Air Resources Board (CARB), and Techtronic Industries North America, Inc., are pleased to explain the Emission Control System Warranty on your non-road or small off-road engine. In California, new small off-road engines must be designed, built, and equipped to meet the state's stringent anti-smog standards. In other states, new 2000 and later model year non-road engines must be designed, built, and equipped at the time of sale to meet the U.S. EPA regulations for small non-road engines. The non-road engine must be free from defects in materials and workmanship which cause it to fail to conform with U.S. EPA standards for the first two years of engine use from the date of sale to the ultimate purchaser. Techtronic Industries North America, Inc., must warrant the emission control system on your non-road or small off-road engine for the period of time listed above provided there has been no abuse, neglect, or improper maintenance of your non-road or small off-road engine.

Your emission control system may include parts such as the carburetor or fuel injection system, the ignition system, and the catalytic converter. Also included may be hoses, belts and connectors, and other emission-related assemblies.

Where a warrantable condition exists, Techtronic Industries North America, Inc., will repair your non-road or small off-road engine at no cost to you, including diagnosis (if the diagnostic work is performed at an authorized service center for RYOBI® brand outdoor products), parts, and labor.

MANUFACTURER'S WARRANTY COVERAGE:

The 1995 and later small off-road engines are warranted for two years in California. In other states, 1997 and later model year non-road engines are also warranted for two years. If any emission-related part on your engine is defective, the part will be repaired or replaced by Techtronic Industries North America, Inc., free of charge.

OWNER'S WARRANTY RESPONSIBILITIES

- (a) As the non-road or small off-road engine owner, you are responsible for the performance of required maintenance listed in your operator's manual. Techtronic Industries North America, Inc., recommends that you retain all receipts covering maintenance on your non-road or small off-road engine, but Techtronic Industries North America, Inc., cannot deny warranty solely for the lack of receipts or for your failure to ensure the performance of all scheduled maintenance. Any replacement part or service that is equivalent in performance and durability may be used in non-warranty maintenance or repairs, and shall not reduce the warranty obligations of the engine manufacturer.
- (b) As the non-road or small off-road engine owner, you should be aware, however, that Techtronic Industries North America, Inc., may deny you warranty coverage if your non-road or small off-road engine or a part has failed due to abuse, neglect, improper maintenance, or unapproved modifications.
- (c) You are responsible for presenting your non-road or small off-road engine to an authorized service dealer as soon as a problem exists. The warranty repairs should be completed in a reasonable amount of time, not to exceed 30 days.

If you have any questions regarding your warranty rights and responsibilities, you should contact a Techtronic Industries North America, Inc., Customer Representative at 1-800-860-4050.

COVERAGE:

Techtronic Industries North America, Inc., warrants to the ultimate purchaser and each subsequent purchaser that your non-road or small off-road engine will be designed, built, and equipped at the time of sale, to meet all applicable regulations. Techtronic Industries North America, Inc., also warrants to the initial purchaser and each subsequent purchaser that your non-road or small off-road engine is free from defects in materials and workmanship which cause the engine to fail to conform with applicable regulations for a period of two years. The 1995 and later small off-road engines are warranted for two years in California. In all other states for 1997 and later model years, EPA requires manufacturers to warrant non-road engines for two years. These warranty periods will begin on the date the non-road or small off-road engine is purchased by the initial purchaser. If any emission-related part on your engine is defective, the part will be replaced by Techtronic Industries North America, Inc., at no cost to the owner.

Techtronic Industries North America, Inc., shall remedy warranty defects at any authorized RYOBI engine dealer or warranty station. Any authorized work done at an authorized dealer or warranty station shall be free of charge to the owner if such work determines that a warranted part is defective. Any manufacturer-approved or equivalent replacement part may be used for any warranty maintenance or repairs on emission-related parts, and must be provided free of charge to the owner if the part is still under warranty. Techtronics North America, Inc., is liable for damages to other engine components caused by the failure of a warranted part still under warranty.

The California Air Resources Board's Emission Warranty Parts List specifically defines the emission-related warranted parts. (EPA's regulations do not include a parts list, but EPA considers emission-related warranted parts to include all the parts listed below.)

These warranted parts are: Carburetor, Spark Plug, Ignition, Air Filter, and Fuel Filter.

MAINTENANCE REQUIREMENTS

The owner is responsible for the performance of the required maintenance as defined by Techtronic Industries North America, Inc., in the operator's manual.

LIMITATIONS

The Emission Control Systems Warranty shall not cover any of the following:

- (a) repair or replacement required because of misuse or neglect, lack of required maintenance, repairs improperly performed, or replacements not conforming to Techtronic Industries North America, Inc., specifications that adversely affect performance and/or durability, and alterations or modifications not recommended or approved in writing by Techtronic Industries North America, Inc., and
- (b) replacement of parts and other services and adjustments necessary for required maintenance at and after the first scheduled replacement point.

The Emissions Compliance Period referred to on the Emissions Compliance label indicates the number of operating hours for which the engine has been shown to meet Federal emission requirements. Category C=50 hours, B=125 hours, and A=300 hours.



OPERATOR'S MANUAL

30CC STRING TRIMMER WITH EXPAND-IT™ EDGER ATTACHMENT

RY30130

- **SERVICE**

Now that you have purchased your tool, should a need ever exist for repair parts or service, simply contact your nearest Authorized Service Center. Be sure to provide all pertinent facts when you call or visit. Please call 1-800-860-4050 for your nearest Authorized Service Center.

- **MODEL NO. AND SERIAL NO.**

The model number of this tool will be found on a plate attached to the motor housing. Please record the model number and serial number in the space provided below.

- **HOW TO ORDER REPAIR PARTS**

When ordering repair parts, always give the following information:

- MODEL NUMBER RY30130
- SERIAL NUMBER _____

Ryobi® is a registered trademark of Ryobi® Limited used under license.

TECHTRONIC INDUSTRIES NORTH AMERICA, INC.

1428 Pearman Dairy Road, Anderson, SC 29625

Phone 1-800-860-4050

www.ryobitools.com