

DESCRIPTION

This plunger pump will pump up to 2 GPM at 2500 PSI. It spins at 3400 RPM in a direct drive system coupled with a gasoline engine. The matching flange provides convenient connection to most 7/8" shaft 1.1 - 5.5 HP engines. The hollow shafted pump includes a built-in pressure control valve, and chemical injection system.

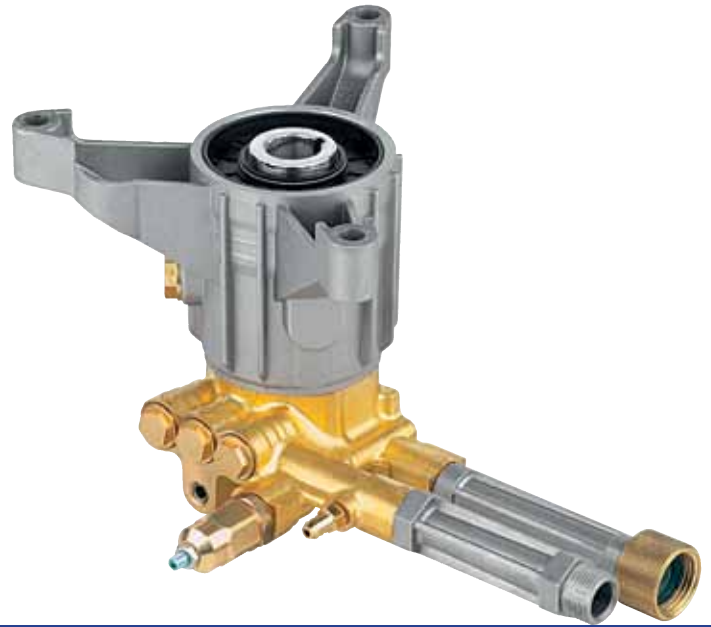

SPECIFICATIONS

MAX GPM	2	MAX LMP	7.6
MAX PSI	2500	MAX BAR	172
POWER EBHP	3.4	BORE DIA. MM	12
STROKE MM	8.3	WEIGHT LBS	7.5
MAX TEMP	140°	OIL CAPACITY	2.2 OZ
INLET THREAD	3/4" GH	DISCHARGE THREAD	22MM

DIMENSIONS

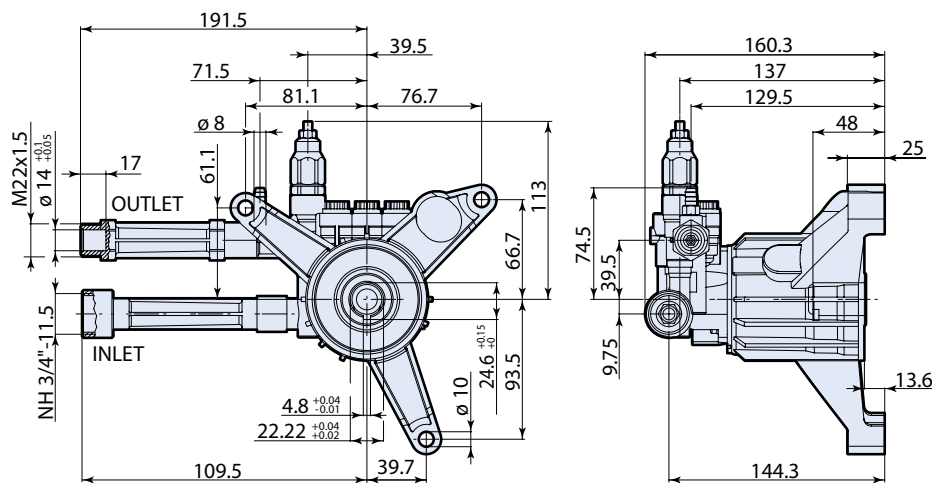

Measurements are - mm

FEATURING

Manifold: Forged brass for long term use.

Bolts: Three 6mm cadmium plated steel.

Plungers: Hardened stainless steel.

Valves: Stainless steel poppet, seat and cage, stainless steel spring.

Seals: Buna-N dual seals.

Bearings: Premium oversized ball and needle bearings.

Crankshaft: Precision die-cast, with cooling fins for maximum heat dissipation. The housing retains the crankshaft bearing, oil seal and rear wobble plate bearing support washer.