

Optional Oilers Shown

## 60 Frame Piston Pump

### Models

# 6020 6040

## FEATURES

### Superior Design

- Triplex Uniflow design provides continuous forward liquid flow for smooth operation.
- Wetted cups and floating pistons are lubricated and cooled by pumped liquid for long cup life.
- Mechanically actuated inlet valves give strong lift and easy prime.
- 304 stainless steel discharge valves for wear resistance.
- Oil bath crankcase assures optimum lubrication.
- 100% wetted seal design allows pumped liquid to cool and lubricate for longer life.

### Quality Materials

- Cylinder and sleeve wear surfaces are hard chrome plated 304 stainless steel for maximum durability and abrasion resistance.
- Chrome plated, brass manifolds and optional stainless steel manifolds are strong and corrosion resistant.
- Precision design 304 stainless steel valves and seats are hardened and polished for ultimate seating and extended valve life.
- Chrome-moly crankshaft gives unmatched strength and surface hardness.
- Oversized crankshaft bearings with greater loading capacity mean longer bearing life.

### Easy Maintenance

- Stepped stainless steel piston rod with chrome-plated, stainless steel sleeve allows easy replacement from front of pump.
- All wet-end wear parts are easily serviced without entering crankcase, requiring less time and effort.
- Wear parts are available in convenient kits.

### **⚠ WARNING**

All systems require both a primary pressure regulating device (i.e., regulator, unloader) and a secondary pressure safety relief device (i.e., pop-off valve, safety valve). Failure to install such relief devices could result in personal injury or damage to the pump or to system components. CAT PUMPS does not assume any liability or responsibility for the operation of a customer's high pressure system.

## SPECIFICATIONS

U.S. Measure

Metric Measure

### MODEL 6020

Flow .....60 GPM (227 L/M)  
 Pressure Range.....100 to 1000 PSI (7 to 70 BAR)  
 Bore.....2.205" (56 mm)

### MODEL 6040

Flow .....40 GPM (151 L/M)  
 Pressure Range.....100 to 1500 PSI (7 to 105 BAR)  
 Bore.....1.811" (46 mm)

### COMMON SPECIFICATIONS

RPM .....500 RPM (500 RPM)  
 Stroke .....2.461" (62.5 mm)  
 Crankcase Capacity .....10 Qts. (9.46 L)  
 Maximum Liquid Temperature .....160°F (71°C)

Above 130°F call CAT PUMPS for inlet conditions and elastomer recommendations.

Inlet Pressure Range .....-8.5 to +40 PSI (-0.6 to +2.8 BAR)  
 Inlet Port (1) .....2" NPTF (2" NPTF)  
 Discharge Ports (3).....1-1/4" NPTF (1-1/4" NPTF)  
 Pulley Mounting .....Either Side (Either Side)  
 Shaft Diameter .....1.772" (45 mm)  
 Weight.....235 lbs. (107 kg)  
 Dimensions.....31.4x24.0x12.05" (796.5x610x306 mm)

## ELECTRIC HORSEPOWER REQUIREMENTS

MODEL	FLOW		PRESSURE				RPM	DRIVE
			PSI 800	PSI 1000	PSI 1200	PSI 1500		
	U.S. GPM	L/M	BAR 55	BAR 70	BAR 85	BAR 105		
6020	60	227	32.9	41.1	N/A	N/A	500	Consult CAT PUMPS for Pump & Motor Pulley sizes
	50	189	27.4	34.3	N/A	N/A	417	
	40	151	22.0	27.4	N/A	N/A	333	
6040	40	151	22.0	27.4	32.9	41.1	500	Consult CAT PUMPS for Pump & Motor Pulley sizes
	36	136	19.8	24.7	29.7	37.0	478	
	30	114	16.5	20.6	24.7	30.9	375	

**DETERMINING THE PUMP R.P.M.**  $\frac{\text{Rated G.P.M.}}{\text{Rated R.P.M.}}$  = "Desired" G.P.M. / "Desired" R.P.M.

**DETERMINING THE REQUIRED H.P.**  $\frac{\text{GPM} \times \text{PSI}}{1460}$  = Electric Brake H. P. Required

**DETERMINING MOTOR PULLEY SIZE**  $\frac{\text{Motor Pulley O.D.}}{\text{Pump R.P.M.}}$  =  $\frac{\text{Pump Pulley O.D.}}{\text{Motor R.P.M.}}$

See complete Drive Packages [Incls: Pulleys, Belts, Hubs, Key] Tech Bulletin 003. Refer to pump Service Manual for repair procedure, additional technical information and pump warranty.

*"Customer confidence is our greatest asset"*

# PARTS LIST

ITEM	PART NUMBER		DESCRIPTION	QTY
	6020 MATL	6040 MATL		
2	43048	43048	Key (M14x9x90)	1
5	126532	126532	Screw, HH (M10x40)	8
6	12503	12503	Lockwasher (M10)	8
	126231	126231	Lockwasher (M10)	8
7	12490	12490	Washer, Flat (M10)	8
	126574	126574	Washer, Flat (M10)	8
8	29443	29443	Case, Bearing, Outer	2
10	29444	29444	O-Ring, Bearing Case - 70D	2
11	11443	11443	Seal, Oil, Crankshaft - 70D	2
15	29441	29441	Bearing, Roller	2
16	29442	29442	Case, Bearing, Inner	2
17	29444	29444	O-Ring, Bearing Case - 70D	2
20	126612	126612	Rod, Connecting (Incls: 21, 22)	3
21	126560	126560	Washer, Locking	3
22	126593	126593	Washer, Shim	6
25	29440	29440	Crankshaft, M62.5	1
31	828710	828710	Protector, Oil Cap w/Foam Gasket	1
32	43211	43211	Cap, Oil Filler	1
33	14177	14177	O-Ring, Cap - 70D	1
34	126743	126743	Bolt, Eye (M12) (For lifting pump only)	1
38	11338	11338	O-Ring, Dipstick - 70D	1
39	27769	27769	Dipstick	1
40	80288	80288	Screw, HH (M10x30)	8
	126531	126531	Screw, HH (M10x30)	8
41	12503	12503	Lockwasher (M10)	8
	126231	126231	Lockwasher (M10)	8
42	12490	12490	Washer, Flat (M10)	8
	126574	126574	Washer, Flat (M10)	8
48	25625	25625	Plug, Drain (1/4x19BSP)	1
49	23170	23170	O-Ring, Drain Plug - 70D	1
50	29438	29438	Cover, Rear	1
51	29439	29439	Gasket, Rear Cover	1
53	45303	45303	Crankcase w/Guide Pins (Incls: 34, 54)	1
55	126554	126554	Stud (M16x72)	4
64	29481	29481	Pin, Crosshead	3
65	43809	43809	Rod, Piston	3
69	126588	126588	Washer, Oil Seal	3
70	29454	29454	Seal, Oil, Crankcase - 80D	3
75	29340	29340	Slinger, Barrier	3
77	13967	13967	O-Ring, Sleeve	6
	14308	14308	O-Ring, Sleeve	6
80	43129	43129	Sleeve (M25)	3
	43271	43271	Sleeve (M25) (Unchromed)	3
81	29455	29455	Back-up-Ring, Sleeve	3
100	29456	29456	Retainer, Seal	3
101	43136	43136	Wick, Oil (M25)	3
106	43130	43130	Seal, LPS Ungreased (M25)	3
	43132	43132	Seal, LPS Ungreased (M25)	3
110	43283	43283	Manifold, Inlet	1
	29805	29805	Manifold, Inlet	1
117	88902	88902	Stud (M16x277)	4
119	29460	43200	Valve, Inlet	3
133	29461	43201	Cup-Piston Assy w/S-Piston	3
	30609	30837	Cup-Piston Assy w/FPM O-Ring (1000 PSI Max)	3
	30646	—	Cup-Piston Assy w/FPM O-Ring (1000 PSI Max)	3
135	29463	29463	Spacer, Piston	3
136	29464	43203	Retainer, Piston	3
137	44272	44272	Washer, Conical (M14)	3
	88582	88582	Washer, Conical (M14)	3
138	29465	29465	Nut, Slotted (M14)	3
139	29354	29354	Cotterpin (M2.5x25)	3
143	12392	12392	O-Ring, Cylinder - 70D	6
	13279	13279	O-Ring, Cylinder - 70D	6
150	29466	43204	Cylinder	3
	43279	43392	Cylinder (Unchromed)	3
153	23116	23116	Back-up-Ring, Cylinder	3
162	—	43206	Back-up-Ring, Seat	3
163	29471	29471	O-Ring, Seat	3
	29479	29479	O-Ring, Seat	3
164	43205	43205	Seat	3
166	29468	29468	Valve	3
167	29469	29469	Spring	3
168	43143	43143	Retainer, Spring	3
185	29472	29472	Manifold, Discharge	1
	29806	29806	Manifold, Discharge	1
186	12504	12504	Lockwasher (M16)	12
	126569	126569	Lockwasher (M16)	12
187	29473	29473	Bolt (M16x225)	4
194	88853	88853	Nut, Hex (M16)	8
196	29476	29476	Plug (1-1/4" NPT)	1
197	22187	22187	Plug (3/8" NPT)	1

# EXPLODED VIEW

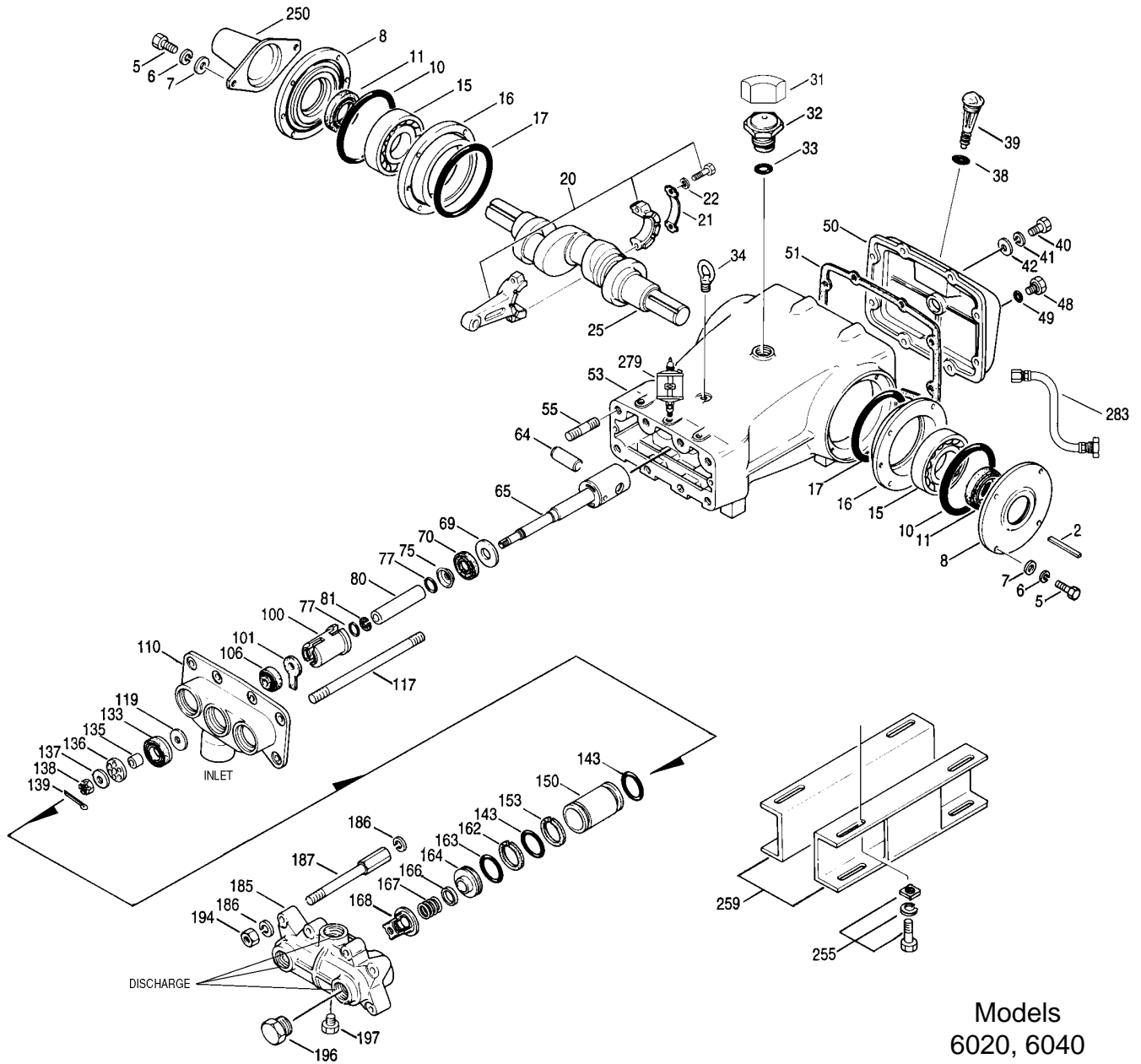

Models  
6020, 6040  
February 2008

	<b>6020</b>	<b>MATL</b>	<b>6040</b>	<b>MATL</b>		
250	29445	AL	29445	AL	Protector, Shaft (Included with Pump)	1
255	33243	STZP	33243	STZP	Mount, Direct (Included with Pump)	1
259	29477	STZP	29477	STZP	Mounting, Rail (Included 2 with Pump)	2
275	—	—	—	—	Hub & Key Assy [See complete Drive Packages, Tech Bulletin 003]	1
279	30429	STZP	30429	STZP	Oilers (10 oz.)	3
281	30969	—	30969	—	Oilers, Glass (10 oz.)	3
282	10070	NBR	10070	NBR	Gasket, Oiler (10 oz.)	3
283	34314	—	34314	—	Kit, Oil Drain	1
300	<b>30440</b>	<b>NBR</b>	<b>30433</b>	<b>NBR</b>	Kit, Cup (Incls: 133,139,143)	1
302	<b>30439</b>	<b>NBR</b>	—	—	Kit, Piston (Incls: 119,133,135,136,137,138,139,143)	1
305	30485	NBR	30485	NBR	Kit, Sleeve & Seal (Incls: 75,77,80,81,101,106,139)	1
306	30484	NBR	30484	NBR	Kit, Seal (Incls: 101,106,139)	1
310	30441	NBR	30441	NBR	Kit, Valve (Incls: 143,162,163,164,166,167,168)	1
—	717500	SS	714500	SS	C.A.T. (Captive Acceleration Tube)	1
—	717508	SS	714508	SS	Adapter (2 per C.A.T.) (See Data Sheet for complete selection)	2
—	6105	—	6105	—	Oil, Twin Pack (2-2.5 gal) ISO 68 Multi-Viscosity Hydraulic (Fill to specified crankcase capacity prior to start-up)	1

**Bold part numbers are unique to a particular pump model.** *Italics are optional items.* R Components comply with RoHS Directive.

See Tech Bulletins 002, 003, 024, 035, 036, 074, 077, 083 and 084 for additional information.

**C.A.T. highly recommended for pressurized inlet, R.O. and Industrial applications.**

MATERIAL CODES (Not Part of Part Number): ABS=ABS Plastic AL=Aluminum BBBCP=Brass/Chrome Plated BBHS=Brass/High Strength CM=Chrome-Moly  
FCM=Forged Chrome-Moly FPM=Fluorocarbon NBR=Medium Nitrile (Buna-N) PTFE=Pure Polytetrafluoroethylene S=304SS SCP=304SS/Chrome Plated SS=316SS  
SSZZ=316SS/Zamak STCP=Steel/Chrome Plated STL=Steel STZP=Steel/Zinc Plated TG=PTFE Graphite Compound (GIT) TR=PTFE-RLN

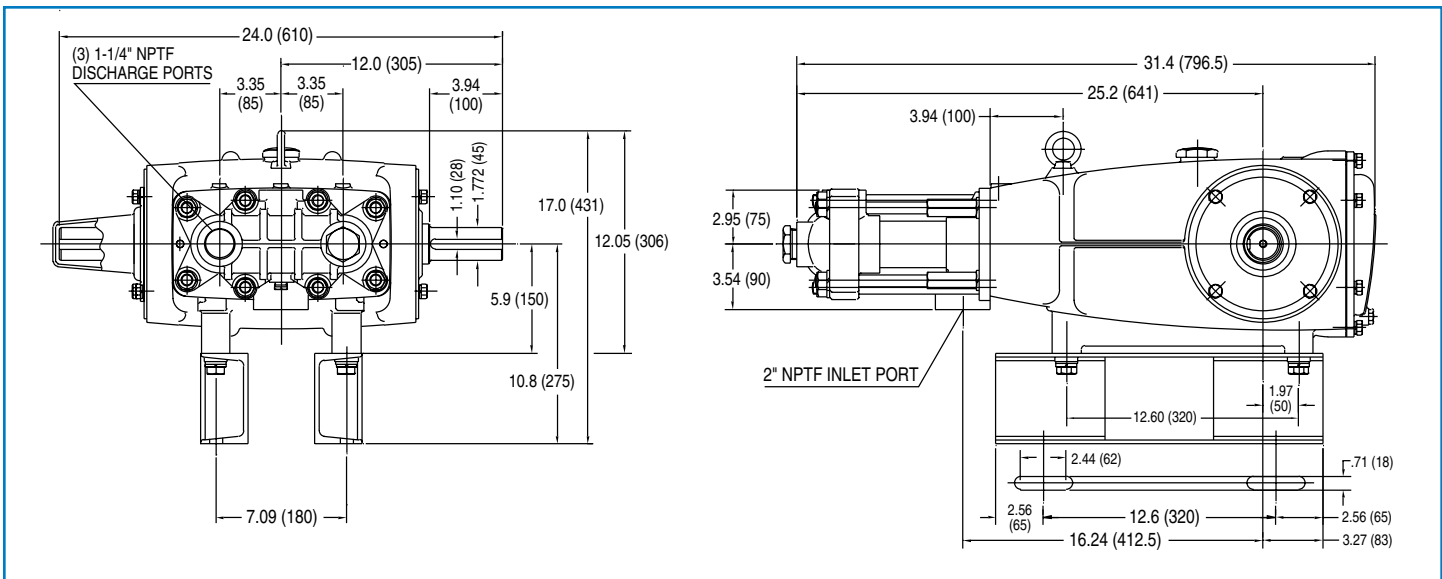

Models 6020, 6040

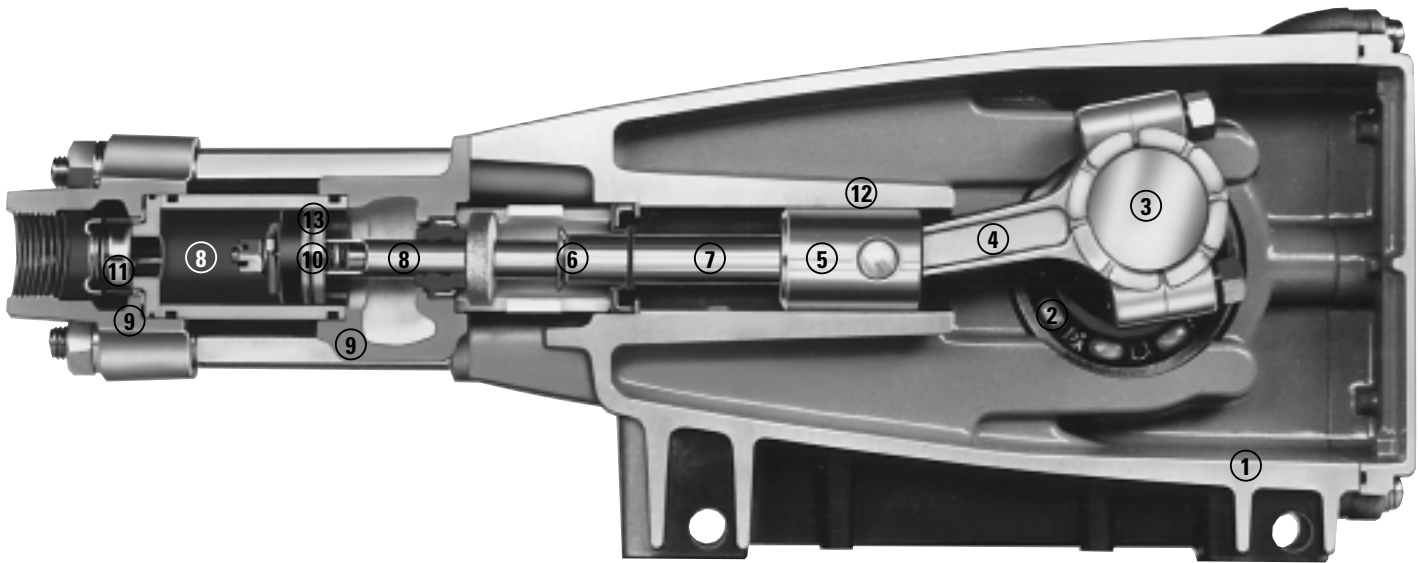

- 1 Die cast aluminum **crankcase** means high strength, lightweight, and excellent tolerance control.
- 2 Oversized crankshaft **bearings** provide extended bearing life and pump performance.
- 3 Chrome-moly **crankshaft** provides unmatched strength and surface hardness for long life.
- 4 Matched oversized high strength **connecting rods** are noted for superior tensile strength and bearing quality.
- 5 The **piston rods** are high tensile strength 316 stainless steel with Zamak crossheads.
- 6 The stainless steel **slinger** provides back-up protection for the crankcase seal, keeping pumped liquids out of the crankcase.
- 7 The **patented stepped piston rod** with stainless steel **sleeves** provides a durable wear surface and easy wet-end servicing.
- 8 The **cylinder** and **sleeve** wear surfaces are hard chrome-plated 304 stainless steel for longer service life.
- 9 **Manifolds** are of high tensile strength chrome-plated brass or 316 stainless steel for special corrosion resistance.
- 10 100% wet **cup/seal** design adds to service life by allowing pumped liquids to cool and lubricate the elastomers on both sides.
- 11 304 stainless steel **valves, seats, and springs** provide corrosion-resistance, ultimate seating and extended life.
- 12 **Crossheads** are 360° supported for uncompromising alignment.
- 13 Mechanically actuated **inlet valves** provide strong lift and easy prime.

**World Headquarters**  
**CAT PUMPS**  
 1681 - 94th Lane N.E. Minneapolis, MN 55449-4324  
 Phone (763) 780-5440 — FAX (763) 780-2958  
 e-mail: techsupport@catpumps.com  
 www.catpumps.com

**International Inquiries**  
 FAX (763) 785-4329  
 e-mail: intlsales@catpumps.com



**CAT PUMPS (U.K.) LTD.**  
 1 Fleet Business Park, Sandy Lane, Church Crookham  
 FLEET, Hampshire, GU52 8BF, England  
 Phone Fleet 44 1252-622031 — Fax 44 1252-626655  
 e-mail: sales@catpumps.co.uk

**N.V. CAT PUMPS INTERNATIONAL S.A.**  
 Heiveldekens 6A, B-2550 Kontich, Belgium  
 Phone 32-3-450.71.50 — Fax 32-3-450.71.51  
 e-mail: cpi@catpumps.be www.catpumps.be

**CAT PUMPS DEUTSCHLAND GmbH**  
 Buchwiese 2, D-65510 Idstein, Germany  
 Phone 49 6126-9303 0 — Fax 49 6126-9303 33  
 e-mail: catpumps@t-online.de www.catpumps.de