

Parts Manual

Mfg. No: 1038-0
1,750 PSI



Model Components	Page
Pressure Washer.....	4
Pump.....	6
Torque Specification Chart.....	8

Not For
Reproduction

Pressure Washer

Note: Unless noted otherwise, use the standard torque specifications

Mfg. No: 1038-0

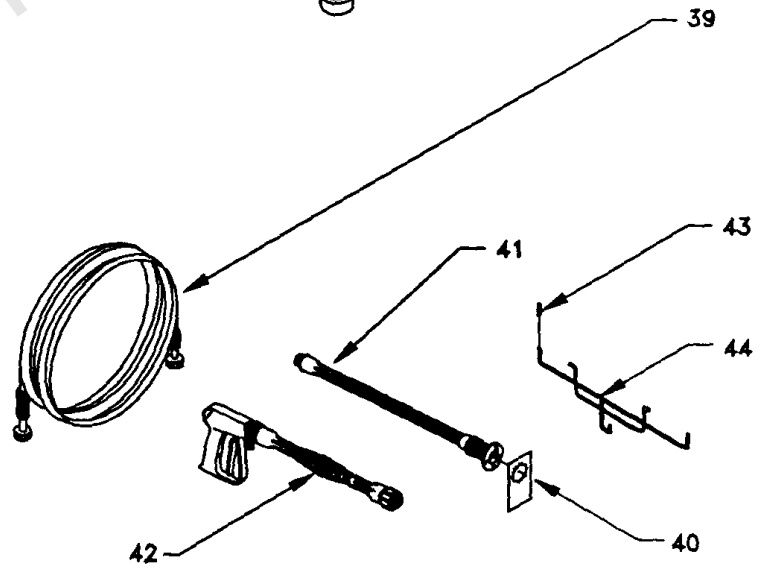
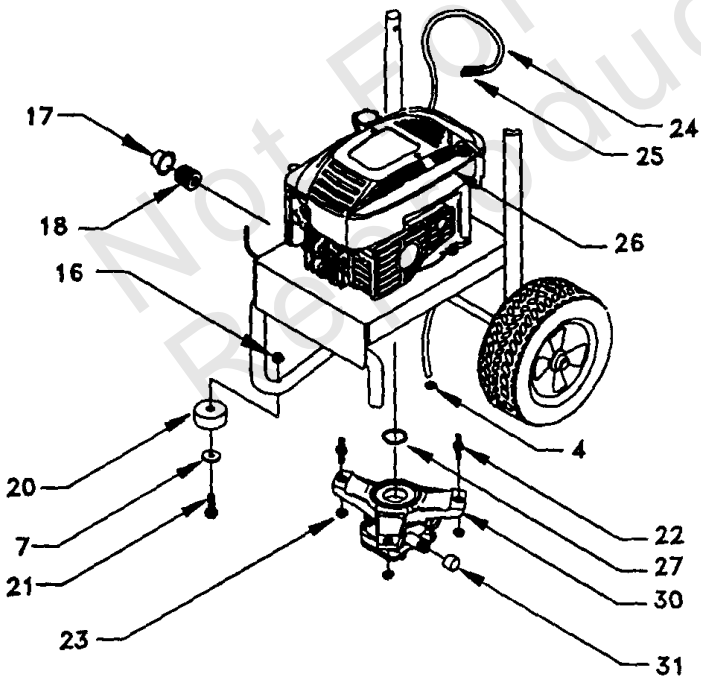
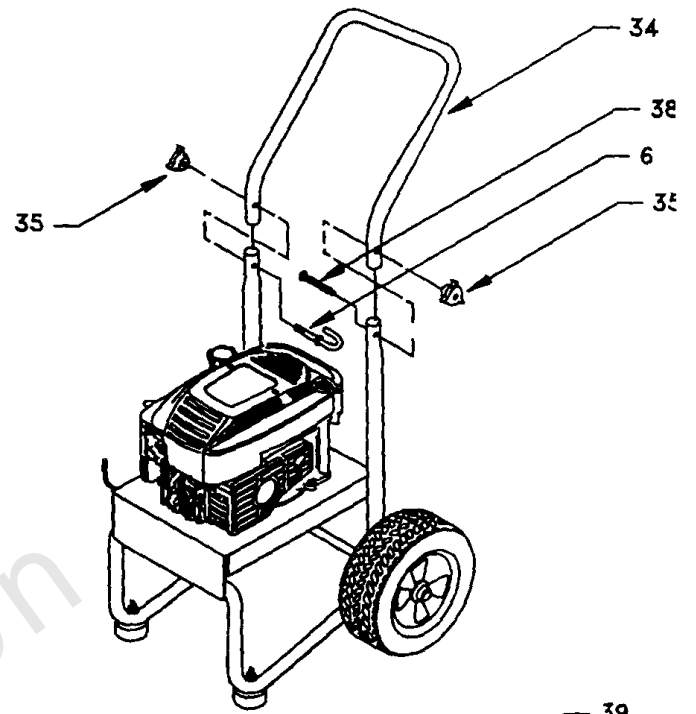
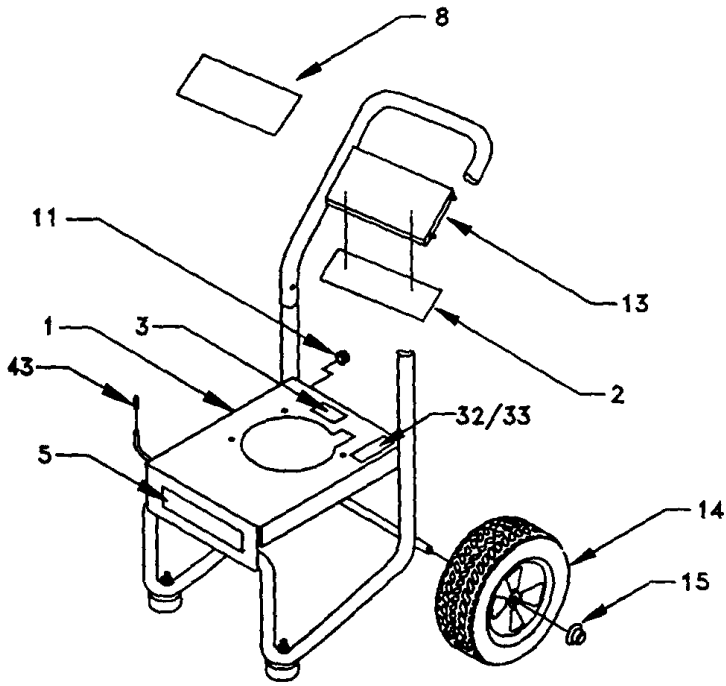

Pressure Washer

REF NO	PART NO	QTY	DESCRIPTION
1	AB2058	1	BASE, VSPW
2	B1932	1	DECAL, Instructions
3	20566	1	DECAL, 1-800 Number
4	48031G	1	CLAMP, Hose 3/16"
5	B2192	1	DECAL, GENERAC
6	B1730	1	BOLT, Eye
7	50190	2	WASHER, M8 Flat
8	B2037	1	DECAL, Logo 1750 PSI
11	30809	1	GROMMET, Chem Hose
13	B1631B	1	BILLBOARD, Plastic
14	B1760	2	TIRE, 3.5" X 10" Black Mag
15	75402	2	PUSHNUT, 1/2"
16	52858	2	NUT, M8 Locking Flange
17	A1408	1	CAP, Garden Hose Inlet
18	21424	1	CONNECTOR, Garden Hose
20	27007	2	MOUNT, Rubber Foot
21	B1214	2	HHCS, M8 X 1.25 X 45 Long
22	B1735	3	STUD, Double Ended
23	B1880	3	NUT, with Washer
24	A1040C	1	HOSE, Chemical
25	A1041	1	FILTER, Chemical Hose
26	B2222	1	ENGINE, Briggs & Stratton 5HP Quantum
27	98300	1	SEAL, Engine Donut
30	-----	1	ASSY, Pump EG with Thermal -(For replacement, order 209940GS)
30	209940GS	1	REPLACEMENT PUMP ASSEMBLY
31	97100	1	CAP, High Pressure
32	88056	1	DECAL, Data
33	79552	1	OVERLAMINATE
34	AB1945	1	HANDLE, VS PW
35	97178	2	KNOB, PW Handle
38	31669	1	BOLT, 1/4"-20 X 1.75" Carriage
39	B1969	1	HOSE, 1/4" X 25'
40	97566	1	HANG TAG, Nozzle
41	B1867F	1	WAND, Adjustable Nozzle
42	B1861	1	GUN, High Pressure
43	B1460	3	CAP, Vinyl Black
44	B1953	1	WIREFORM

Pump

Note: Unless noted otherwise, use the standard torque specifications

Mfg. No: 1038-0

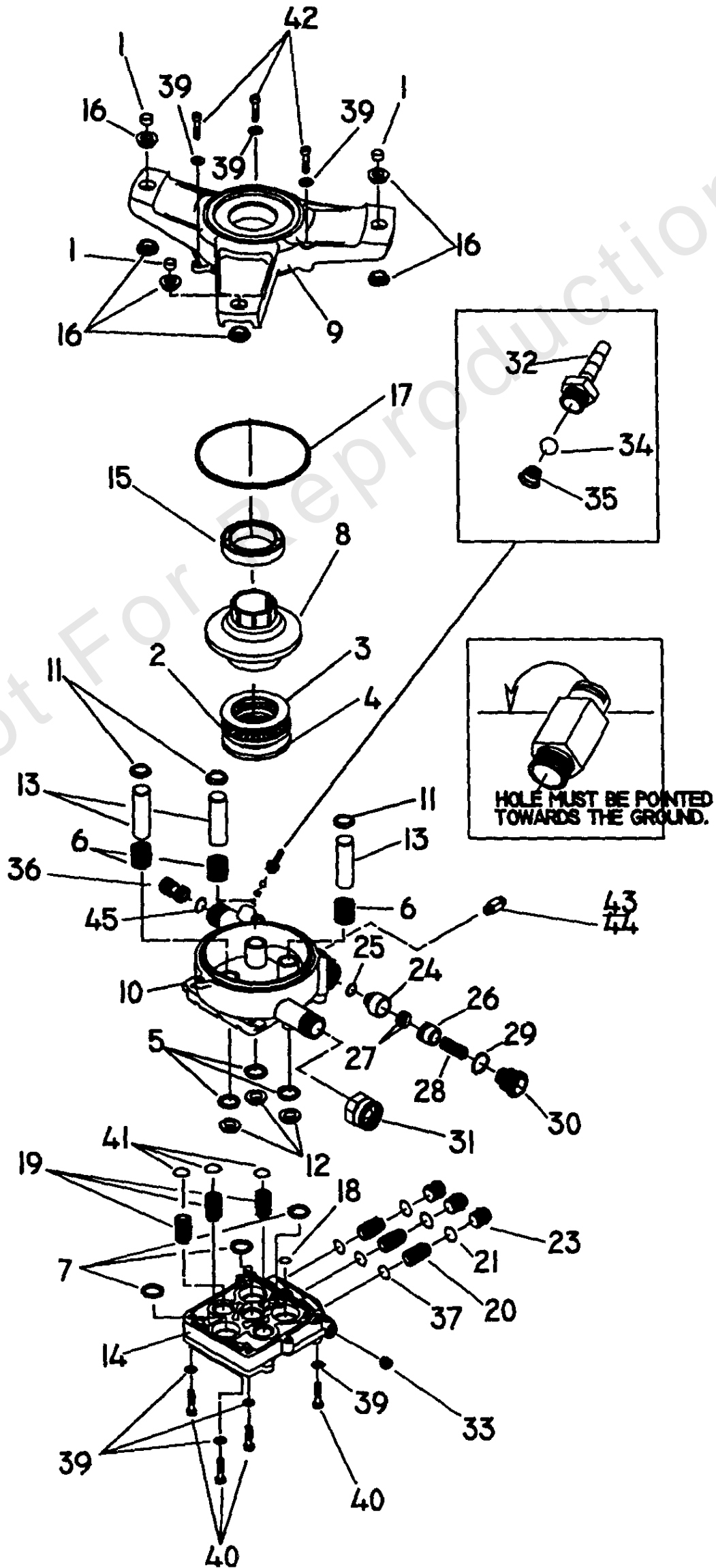

Pump

REF NO	PART NO	QTY	DESCRIPTION
1	96795	3	SLEEVE, RUBBER GROMMET SPACER
2	21640	1	ASSY., CAGE NEEDLE BEARING 45 X 65
3	21641	1	WASHER, BRG. DIA. 45 x 65 x 1T
4	21642	1	WASHER, BRG. DIA. 36 x 65 x 6T -[SPECIAL]
5	93680	3	SEAL, OIL PISTON DIA. 15
6	97828	3	SPRING, PISTON RETURN - EG
7	93667	3	SEAL, U-CLIP
8	98304	1	CAM, AXIAL 5.6mm w/INSERT
9	98227	1	ADAPTER, ENGINE
10	20110	1	HOUSING, PISTON AND UNLOADER
11	97830	3	RETAINER, PISTON SPRING
12	97831	3	SPACER, PILOT
13	97832	3	PISTON, DIA. 15-65 LONG
14	A1111B	1	HEAD, PUMP
15	57018	1	BEARING, BALL RADIAL
16	21429	6	BUSHING, RUBBER
17	97835	1	"O" RING, HOUSING SEAL
18	97837	1	"O" RING, HI-PRESSURE TRANSFER
19	97838	3	ASS'Y, CHECK VALVE - INLET
20	97839	3	ASS'Y, CHECK VALVE - OUTLET
21	97840	3	"O" RING, INLET PORT CAP
23	97841	3	CAP, INLET PORT
24	97842	1	SEAT, UNLOADER
25	97843	1	"O" RING, UNLOADER VENTURI
26	B1253	1	PISTON, UNLOADER
27	97845	2	SEAL, UNLOADER "PARBACK"
28	A2731	1	SPRING, UNLOADER
29	97847	1	"O" RING, UNLOADER CAP
30	A2730	1	CAP, UNLOADER
31	21424	1	GARDEN HOSE CONNECTOR
32	A1575	1	BARB, HOSE WITH NYLON INSERT
33	96137	1	PLUG, 1/8" NPT [WITH SEALANT]
34	95379	1	BALL, DIA. 5.5 CHEMICAL INJECTOR
35	95380	1	SPRING, CHEMICAL INJECTOR
36	20631	1	VENTURI, CHEMICAL INJECTOR
37	97934	3	"O" RING, CHECK VALVE - INLET
39	93873	7	LOCK WASHER, M6 RIBBED
40	40946	4	SOCKET HEAD CAPSCREW M6-1.0 x 35mm
41	97851	3	"O" RING PISTON HOUSING
42	97962	3	SOCKET HEAD CAPSCREW, M6-1.0 x 25mm
43	21783	1	THERMAL RELIEF
44	20876	0	.5 OZ. SEALANT, THREAD LOCKTITE 545
45	B1077	1	"O" RING VENTURI

Hardware Identification & Torque Specifications

Torque Specification Chart								
FOR STANDARD METRIC MACHINE HARDWARE (Tolerance ± 20%)								
Property Class	5.6		8.8		10.9		12.9	
	Class 5.6		Class 8.8		Class 10.9		Class 12.9	
Size Of Hardware	in/lbs	Nm.	in/lbs	Nm.	in/lbs	Nm.	in/lbs	Nm.
	ft/lbs		ft/lbs		ft/lbs		ft/lbs	
M3	5.88	.56	13.44	1.28	19.2	1.80	22.92	2.15
M4	13.44	1.28	30.72	2.90	43.44	4.10	52.56	4.95
M5	26.4	2.50	60.96	5.75	5.97	8.10	7.15	9.7
M6	44.64	4.3	7.3	9.9	10.3	14	12.1	16.5
M7	5.2	7.1	12.1	16.5	16.9	23	19.9	27
M8	7.7	10.5	17.7	24	25	34	29	40
M10	15	21	35	48	50	67	59	81
M12	26	36	61	83	86.2	117	103	140
M14	42	58	101	132	136	185	162	220
M16	64	88	147	200	210	285	250	340
M18	89	121	202	275	287	390	346	470
M20	126	171	290	390	405	550	486	660
M22	169	230	390	530	559	745	656	890
M24	217	295	497	375	708	960	840	1140
M27	320	435	733	995	1032	1400	1239	1680
M30	435	590	995	1350	1401	1900	1681	2280
M33	590	800	1349	1830	1902	2580	2278	3090
M36	759	1030	1740	2360	2441	3310	2935	3980
M39	988	1340	2249	3050	3163	4290	3798	5150

Torque Specification Chart						
FOR STANDARD MACHINE HARDWARE (Tolerance ± 20%)						
Hardware Grade	No Marks		SAE Grade 5		SAE Grade 8	
	SAE Grade 2		SAE Grade 5		SAE Grade 8	
Size Of Hardware	in/lbs	Nm.	in/lbs	Nm.	in/lbs	Nm.
	ft/lbs		ft/lbs		ft/lbs	
8-32	19	2.1	30	3.4	41	4.6
8-36	20	2.3	31	3.5	43	4.9
10-24	27	3.1	43	4.9	60	6.8
10-32	31	3.5	49	5.5	68	7.7
1/4-20	66	7.6	8	10.9	12	16.3
1/4-28	76	8.6	10	13.6	14	19.0
5/16-18	11	15.0	17	23.1	25	34.0
5/16-24	12	16.3	19	25.8	29	34.0
3/8-16	20	27.2	30	40.8	45	61.2
3/8-24	23	31.3	35	47.6	50	68.0
7/16-14	30	40.8	50	68.0	70	95.2
7/16-20	35	47.6	55	74.8	80	108.8
1/2-13	50	68.0	75	102.0	110	149.6
1/2-20	55	74.8	90	122.4	120	163.2
9/16-12	65	88.4	110	149.6	150	204.0
9/16-18	75	102.0	120	163.2	170	231.2
5/8-11	90	122.4	150	204.0	220	299.2
5/8-18	100	136	180	244.8	240	326.4
3/4-10	160	217.6	260	353.6	386	525.0
3/4-16	180	244.8	300	408.0	420	571.2
7/8-9	140	190.4	400	544.0	600	816.0
7/8-14	155	210.8	440	598.4	660	897.6
1-8	220	299.2	580	788.8	900	1,244.0
1-12	240	326.4	640	870.4	1,000	1,360.0

The guides and ruler furnished below are designed to help you select the appropriate hardware.



Nut, M8

Thread Diameter (mm)

Inside Diameter (in) Threads per inch

Nut, 1/2-16



Screw, M8- 1.25 x 25

Thread Diameter (mm) Distance between threads (mm) Body Length (mm)

Body Diameter Threads per inch Body Length (in)

Screw, 1/2- 16 x 2



Standard Hardware Sizing

When a washer or nut is identified as 1/2" (M8), this is the *Nominal size*, meaning the *inside diameter* is 1/2 inch (8mm metric thread diameter); if a second number is present it represents the *threads per inch* (distance between threads).

When bolt or capscrew is identified as 1/2 - 16 x 2" (M8 - 1.25 x 50), this means the *Nominal size*, or body diameter is 1/2 inch (8mm metric thread diameter), the second number, 16, represents the *threads per inch*, (*distance between threads*). The final number is the body length of the bolt or screw, 2 inches (50mm).

NOTES

- These torque values are to be used for all hardware excluding: locknuts, self-tapping screws, thread forming screws, sheet metal screws and socket head setscrews.
- Recommended seating torque values for locknuts:
 - for prevailing torque locknuts - use 65% of grade 5 torques.
 - for flange whizlock nuts and screws - use 135% of grade 5 torques.
- Unless otherwise noted on assembly drawings, all torque values must meet this specification.

Common Hardware Types

Hex Head Capscrew



Washer



Carriage Bolt



Hex Nut

Wrench & Fastener Size Guide

1/4" Bolt or Nut Wrench—7/16"	5/16" Bolt or Nut Wrench—1/2"	3/8" Bolt or Nut Wrench—9/16"	7/16" Bolt or Nut Wrench (Bolt)—5/8" Wrench (Nut)—11/16"	1/2" Bolt or Nut Wrench—3/4"
M6 Bolt or Nut Wrench—10mm	M8 Bolt or Nut Wrench—13mm	M10 Bolt or Nut Wrench—17mm	M12 Bolt or Nut Wrench—19mm	M14 Bolt or Nut Wrench—22mm

