

PRODUCT DATA SHEET

XMA-SS0.5G15E-F33 - 1750 RPM

DESCRIPTION

In high frequency and long time operation, high accurate manufacturing technique is the only answer to the durable reputation Annovi Reverberi pumps. The S.S. Series uses include various applications such as reverse osmosis water desalination, seal gland flushing and waste water odor control. S.S. Series feature a SAE 316 stainless steel manifold this is totally corrosion-resistance. Special pumps features include our highly concentric bearing positioning on both sides of the crankcase, anticorrosion coated aluminum die cast crankcase, continuously lubricated Viton seals, triple lip loaded oils seals and our ultra thick ceramic plungers that will not crack under extreme variable temperature conditions.

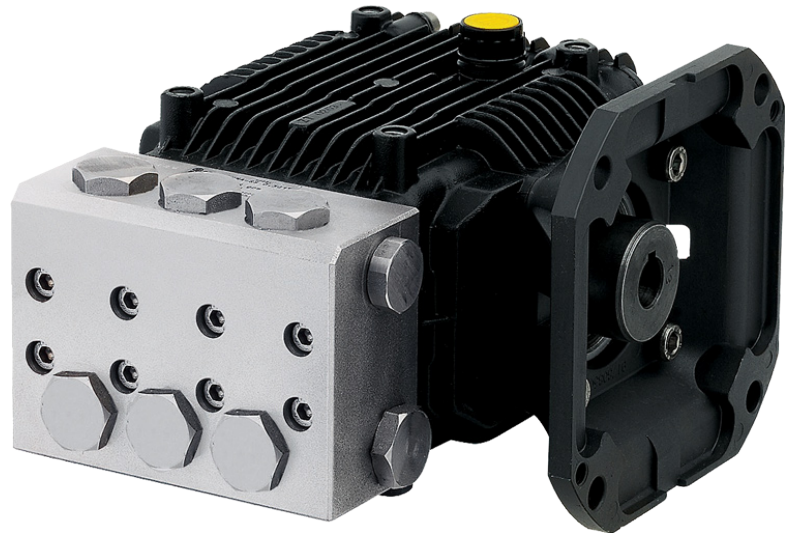

SPECIFICATIONS

MAX GPM	0.5	MAX LMP	1.9
MAX PSI.....	1500	MAX BAR	105
POWER EBHP	0.05	BORE DIA. MM.....	15
STROKE MM.....	2.2	WEIGHT LBS.....	17
MAX TEMP	140°	OIL CAPACITY.....	14.5oz
INLET THREAD	1/2" F	DISCHARGE THREAD	3/8" F

DIMENSIONS

XMA-SS E version + F33
Hollow shaft pump \varnothing 5/8"

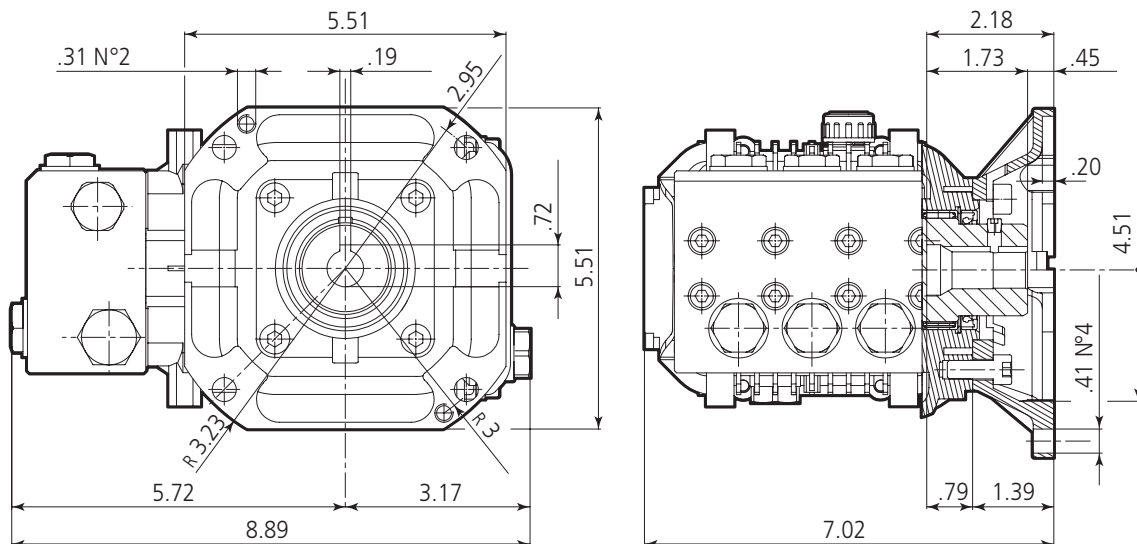

SPECIAL FEATURES

WET END

- **Manifold:**
 - **316L - Stainless Steel Block Style:** Strength and no porosity = long life.
 - **Inlet and Discharge Ports:** 1/2" inlet and 3/8" discharge.
 - **Offset Discharge Ports:** High efficiency, smooth flow
 - **Bolts:** 8 Bolts, 6mm, stainless steel.
- **Valves:**
 - **Ultra Form Cages:** Durable, strength, and long life.
 - **Poppets, Seat and Spring:** 316 series stainless steel.
 - **Valve Caps:** Machined 316L.
- **Packing and Plungers:**
 - **High Pressure Packing:** "V" style (D-1) Viton (cotton duct weave base) strong and tightens under load.
 - **Low Pressure Seals:** "U" cup double lip Viton, good positive seal.
 - **Support and Guides:** Machined stainless steel, 2-piece construction and back-up ring to assure proper plunger alignment, maximize packing and seal life.
 - **Plungers:** Special aluminum oxide blend, solid ceramic long life, strong and durable.

DRIVE END

- **Bearings:** Oversized for maximum life and load dispersement, needle bearing on the drive side and ball on the non-drive side. Each bearing is held in position on the crankshaft and crankcase by snap rings. This assures positive alignment and centering of the connecting rods and crankshaft in relation to the crankcase, it also eliminates the crankshaft from floating.
- **Crankcase:** Precision die-cast, large cooling fins and covered with a special anti-corrosion finish.
- **Rear Cover:** Precision die-cast, O-Ring sealed and bayonet style sight glass for positive sealing and locking (no threads to loosen). This is an "AR" original. Oil drain plug.

- **Plunger Rods:** Stainless steel construction for strength, back-up and O-ring plunger sealing system with SST slingers.
- **Rod Pins:** Precision ground and hardened steel, oversized for load dispersement.
- **Connection Rods:** 1-piece special allow bronze for higher pressures, oversized for maximum strength, load dispersement, and life. Heavy pin area construction.
- **Crankshaft:** Forged, precision ground and hardened for extremely long life and durability. Available in 5/8" hollow shafts drive. Shaft key set screws are standard on high-speed version for long shaft life. Mounting flange is 56-C face.
- **Oil Seals and O-Rings:** All are constructed of Buna-N rubber. The O-rings have stainless steel garder springs to assure constant tension on the sealing surface.
- **Oil Drains:** Two (2). One in the rear cover and one in the bottom of crankcase
- **Oil Capacity:** 14 oz.

EXTRA FEATURES

- **Dyno Proven:** All pumps are dyno tested to assure the theoretical design meets the actual design.
- **Valve Design:** Each pump series has a valve design that optimizes its highest efficiency.
- **Hot Water:** High temperature kits are available to 180°F.
- **Wet End Repair:** Very simple no special tools are required.
- **Two Oil Drain Plugs:** Rear cover and crankcase bottom.
- **Mounting Flanges:** Multiple flanges are available.
- **Mounting Bolt Pattern:** On top and bottom of the crankcase for shaft reversal.
- **Buna-N:** Elastomers available.