

THE WORK PRO[®]

by Mi-T-M[®]

8650 Enterprise Drive, Peosta IA 52068
563-556-7484 / Fax 563-556-1235

PARTS LIST FOR

WP-2003-1MHB

WP-2000-2MIB

Engine Oil Grade:

Honda:

SAE 10W-30

B & S Intek:

Above 40° = SAE30

Below 40° = SAE 10W-30

Engine Oil Capacity:

20 oz.

Pump Oil Grade:

Mi-T-M Pump Oil #AW-4085-0016

Pump Oil Capacity:

4.5 oz.

Nozzle Size:

3.5

This Parts Listing has been compiled for your benefit. You can be assured your Mi-T-M Cold Water Pressure Washer was constructed and designed with quality and performance in mind using over 25 years experience in the pressure washer business. Each component has been rigorously tested to insure the highest level of acceptance.

The contents of this Parts Listing are based on the latest product information available at the time of publication. Mi-T-M reserves the right to make changes in price, color, materials, equipment, specifications or models at any time without notice.

WARNING

THIS IS A PROFESSIONAL HIGH PRESSURE, COLD WATER PRESSURE WASHER. CAUTION SHOULD BE OBSERVED WHEN USING OR REPAIRING THIS UNIT! READ AND FOLLOW THE SAFETY WARNINGS LISTED BELOW BEFORE ATTEMPTING ANY REPAIRS ON THIS PRESSURE WASHER!

SAFETY WARNINGS

1. NEVER alter or modify the equipment. Be sure any accessory items and system components being used will withstand the pressure developed. Use only genuine Mi-T-M parts for repair of your pressure washer. Failure to do so can cause hazardous operating conditions and will VOID warranty.
2. NEVER make adjustments on machinery while the unit is connected to the engine without first removing the ignition cable from the spark plug. Turning over the machinery by hand during adjustment or cleaning might start the engine and machinery with it, causing serious injury to the operator.
3. Know how to stop and bleed pressures quickly. Be thoroughly familiar with controls.
4. Before servicing the unit, turn unit off, relieve the water pressure and allow the unit to cool down. Do not make repairs while the unit is running. Service in a clean, dry, flat area. Block the wheels to prevent the unit from moving. Be especially careful to properly dispose of any flammable materials.
5. After testing the machine, DO NOT leave the pressurized unit unattended. Shut off the unit and release trapped pressure before leaving.

Table of Contents

SPECIFICATIONS	3
FRAME ASSEMBLY FOR WP-2003-1MHB	4
FRAME ASSEMBLY FOR WP-2000-2MIB	6
PUMP ASSEMBLY (3-0191)	8
GUN/WAND ASSEMBLY (16-0364)	10
LANCE ASSEMBLY (16-0366)	12
NOTES	13-15

SPECIFICATIONS

WP-2003-1MHB/2000-2MIB

MODEL NUMBER	WP-2003-1MHB	WP-2000-2MIB
Operating Pressure (PSI/Bar):	2000/138	
High Pressure Nozzle:	3.5	
Water Volume (GPM/lpm):	2.5/9.5	
Engine:	Honda	B & S Intek
Horsepower	5.0	5.5
Engine Type	4 Stroke, Overhead Cam, Single Cylinder	4 Stroke, Overhead Valve, Single Cylinder
Oil Type	SAE10W-30	Above 40 F = SAE30/Below 40 F = SAE10W-30
Oil Capacity (oz./liters)	20/.6	20/.6
Fuel Type	Unleaded Gasoline 86 Octane Minimum	
Fuel Capacity (gallon/ liters)	.5/2	.75/2.8
Starting	Recoil	
Maximum No Load RPM	3600 (+/- 100) RPM	
Pump:	Direct Driven, Oil Bath, Triplex Piston	
Oil Type	Mi-T-M Pump Oil #AW-4085-0016	
Oil Capacity (oz./liters)	4.5/.13	
Plungers	Ceramic Coated	
Manifold	Forged Brass	
Valves	Stainless Steel	
Unloader	Adjustable	
Heat Dump Valve	Relieves heated water during unloader bypass stage	
Detergent Injector	Adjustable low pressure down stream from pump	
Unit Net Weight (lbs/Kg)	75/34	
Unit Shipping Weight (lbs/Kg)	87/39.5	
Unit Net Dimension (in/cm)	30Lx21Wx26H/76Lx53.5Wx66H	
Unit Shipping Dimension (in/cm)	30.5Lx21.5Wx26.5H/77.5Lx54.5Wx67.5H	

FRAME ASSEMBLY FOR WP-2003-1MHB

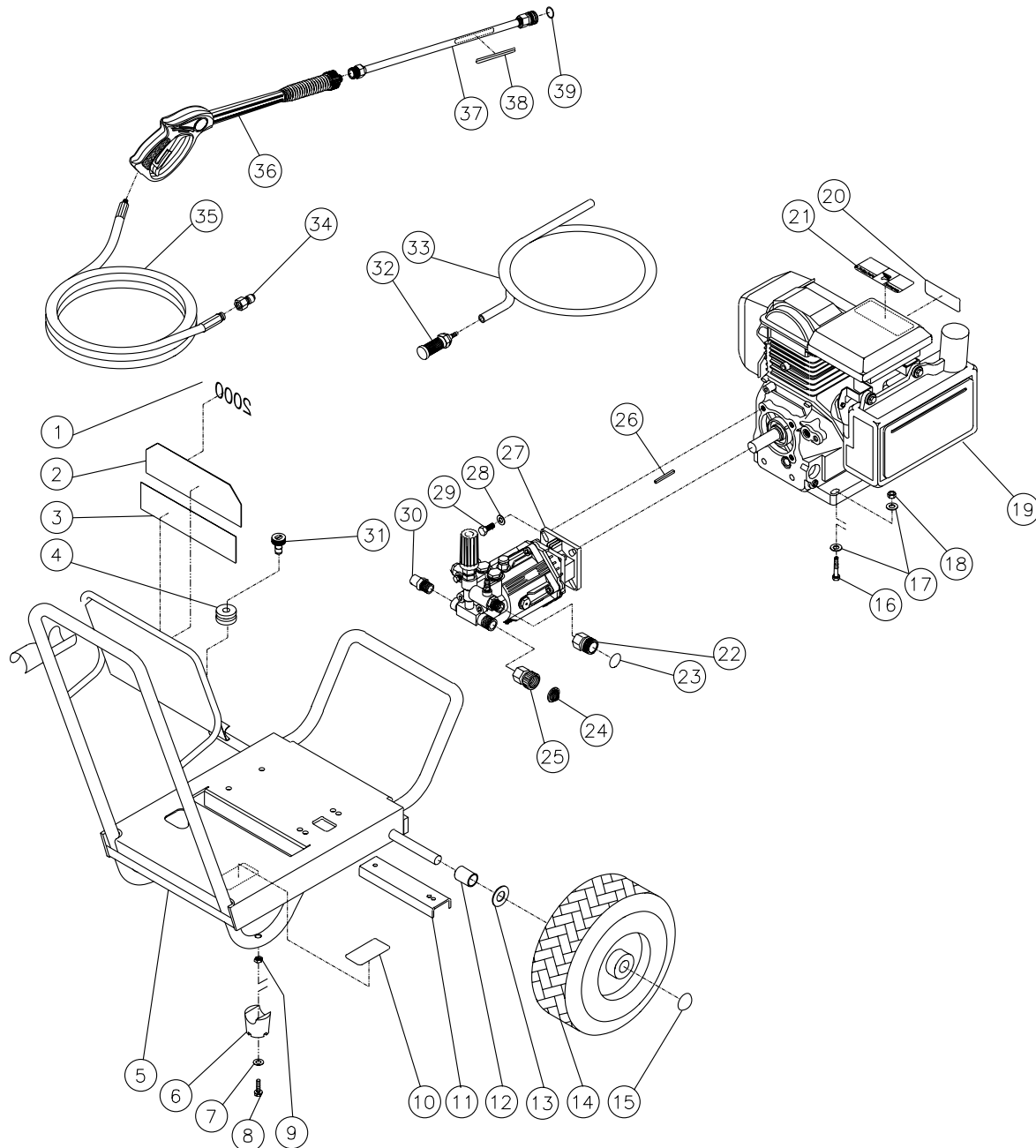

WP-2003-1MHB-020502-RD

FRAME ASSEMBLY FOR WP-2003-1MHB							
REF. #	DESCRIPTION	PART #	QTY.	REF. #	DESCRIPTION	PART #	QTY.
1	Decal- 2000 Die Cut	34-0771	1	22	Fitting	17-0004	1
2	Decal- Placard	34-0737	1	23	O-ring (Replacement Only)	25-0123	-
3	Decal- Warning/Caution/Operating (E/S)	34-1244	1	24	Filter	19-0001	1
4	Grommet	33-0001	5	25	Garden Hose Swivel	23-0001	1
5	Frame	5-0123A20	1	26	Key	43-0073	1
6	Isolator	14-0066	2	27	Pump	3-0191	1
7	Washer	28-0021	2	28	Lockwasher	29-0007	4
8	Bolt	27-0019	2	29	Bolt	27-0846	4
9	Locknut	30-0155	2	30	Heat Dump Valve	22-0208	1
10	Decal- Data Plate	N/A	1	31	Nozzle- 1503.5	18-0258	1
11	Support Base	13-0119A20	1	-	Nozzle- 2503.5	18-0259	1
12	Axle Spacer	20-0313A01	2	-	Nozzle- 6540	18-0148	1
13	Washer	28-0008	5	32	Detergent Strainer	19-0050	1
14	Wheel	14-0080	2	33	Detergent Hose *(Four Feet Required)	15-0021	1
15	Hubcap	33-0018	2	34	Fitting	17-0006	1
16	Bolt	27-0070	4	35	Pressure Hose	15-0138	1
17	Washer	28-0003	8	36	Gun/Wand Assembly	16-0364	1
18	Locknut	30-0157	4	37	Lance Assembly	16-0366	1
19	Engine- 5.0 HP Honda	1-0104	1	38	Decal- Risk of Injection (E/S)	34-1253	1
20	Decal- Caution: Allow to Cool (E/S)	34-0599	1	39	O-ring (Replacement Only)	25-0122	-
21	Decal- Warning: Muffler Hot (E/S)	34-0598	1	*Must Order in One Foot Lengths			

FRAME ASSEMBLY FOR WP-2000-2MIB

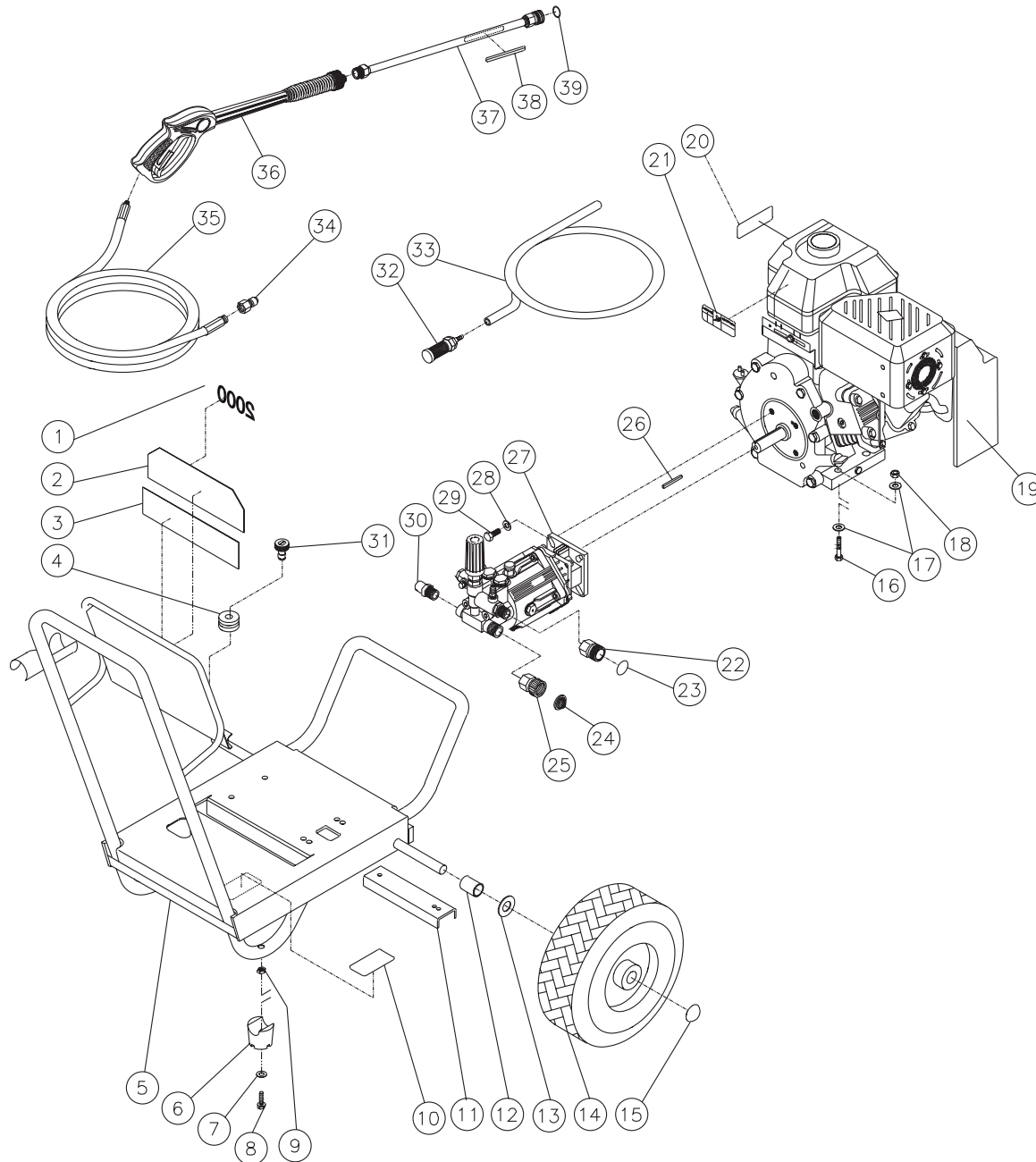

WP-2000-2MIB-021802-RD

FRAME ASSEMBLY FOR WP-2000-2MIB							
REF. #	DESCRIPTION	PART #	QTY.	REF. #	DESCRIPTION	PART #	QTY.
1	Decal- 2000 Die Cut	34-0771	1	22	Fitting	17-0004	1
2	Decal- Placard	34-0737	1	23	O-ring (Replacement Only)	25-0123	-
3	Decal- Warning/Caution/Operating (E/S)	34-1244	1	24	Filter	19-0001	1
4	Grommet	33-0001	5	25	Garden Hose Swivel	23-0001	1
5	Frame	5-0123A20	1	26	Key	43-0073	1
6	Isolator	14-0066	2	27	Pump	3-0191	1
7	Washer	28-0021	2	28	Lockwasher	29-0007	4
8	Bolt	27-0019	2	29	Bolt	27-0846	4
9	Locknut	30-0155	2	30	Heat Dump Valve	22-0208	1
10	Decal- Data Plate	N/A	1	31	Nozzle- 1503.5	18-0258	1
11	Support Base	13-0119A20	1	-	Nozzle- 2503.5	18-0259	1
12	Axle Spacer	20-0313A01	2	-	Nozzle- 6540	18-0148	1
13	Washer	28-0008	5	32	Detergent Strainer	19-0050	1
14	Wheel	14-0080	2	33	Detergent Hose *(Four Feet Required)	15-0021	1
15	Hubcap	33-0018	2	34	Fitting	17-0006	1
16	Bolt	27-0070	4	35	Pressure Hose	15-0138	1
17	Washer	28-0003	8	36	Gun/Wand Assembly	16-0364	1
18	Locknut	30-0157	4	37	Lance Assembly	16-0366	1
19	Engine- 5.5 HP Intek	1-0106	1	38	Decal- Risk of Injection (E/S)	34-1253	1
20	Decal- Caution: Allow to Cool (E/S)	34-0599	1	39	O-ring (Replacement Only)	25-0122	-
21	Decal- Warning: Muffler Hot (E/S)	34-0598	1	*Must Order in One Foot Lengths			

PUMP ASSEMBLY (3-0191)

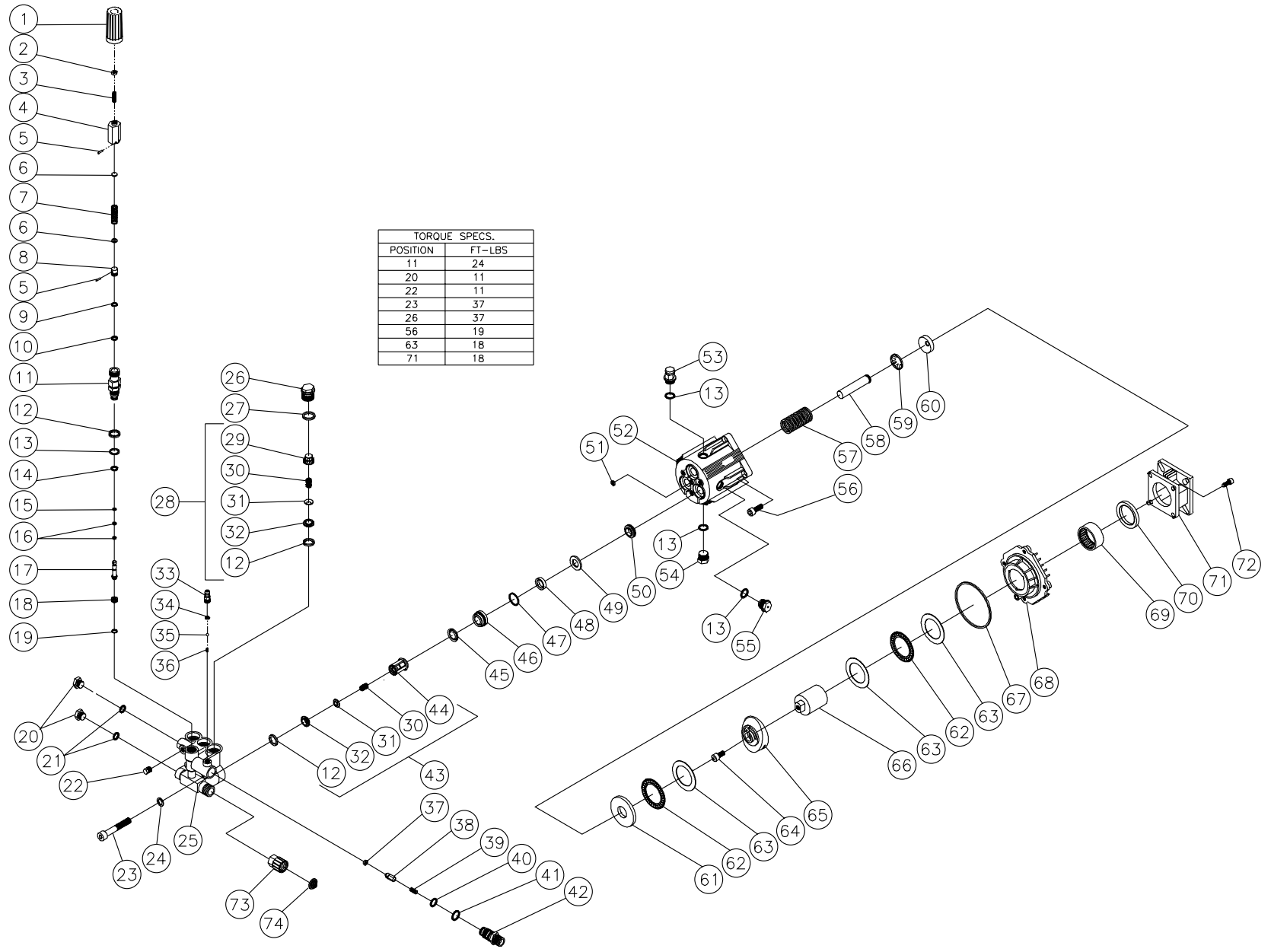

TORQUE SPECS.	
POSITION	FT-LBS
11	24
20	11
22	11
23	37
26	37
56	19
63	18
71	18

3-0191-090100-EDW

PUMP ASSEMBLY (3-0191)											
REF. #	DESCRIPTION	PART #	QTY.	REF. #	DESCRIPTION	PART #	QTY.	REF. #	DESCRIPTION	PART #	QTY.
1	Unloader Knob	7-0163	1	27	O-ring	25-0160	3	53	Oil Cap	39-0118	1
2	Nut	30-6024	1	28	Single Valve Assembly (Inc. 12, 29-32) (See 70-0290)	N/A Sep.	3	54	Plug	39-0086	1
3	Set Screw	27-8959	1	29	Valve Cage (See 70-0290)	N/A Sep.	3	55	Oil Sight Glass	39-0119	1
4	Adjustment Barrel	8-0500	1	30	Valve Spring (See 70-0290)	N/A Sep.	6	56	Bolt	27-8432	4
5	Pin	43-0087	2	31	Valve Plate (See 70-0290)	N/A Sep.	6	57	Spring	49-0142	3
6	Spring Button	8-0501	2	32	Valve Seat (See 70-0290)	N/A Sep.	6	58	Piston	46-0897	3
7	Spring	49-0119	1	33	Hose Barb	46-0869	1	59	Spring Retainer	46-0875	3
8	Poppet	8-0415	1	34	O-ring (See 70-0293)	N/A Sep.	1	60	Piston Shoe	46-0882	3
9	Back-up Ring (See 70-0292)	N/A Sep.	1	35	Ball (See 70-0293)	N/A Sep.	1	61	Washer	46-0876	1
10	O-ring (See 70-0292)	N/A Sep.	1	36	Detergent Injector Spring (See 70-0293)	N/A Sep.	1	62	Bearing	48-0057	2
11	Piston Guide	8-0502	1	37	O-ring	25-0406	1	63	Washer	48-0056	3
12	O-ring	25-0386	7	38	Check Valve	8-0458	1	64	Bolt	27-8884	1
13	O-ring	25-0325	4	39	Spring	49-0124	1	65	Wobble Plate	46-0877	1
14	O-ring (See 70-0292)	N/A Sep.	1	40	O-ring	25-0407	1	66	Shaft	46-0878	1
15	Back-up Ring	25-0408	1	41	O-ring	25-0159	1	67	O-ring	25-0503	1
16	O-ring	25-0253	2	42	Injector Adapter	46-0870	1	68	Pump Flange	46-0879	1
17	Piston	8-0413	1	43	Single Valve Assembly (Inc. 12, 30-32, 44) (See 70-0290)	N/A Sep.	3	69	Bearing	48-0071	1
18	Valve Seat	8-0503	1	44	Support Ring (See 70-0290)	N/A Sep.	3	70	Oil Seal	26-0192	1
19	O-ring	25-0500	1	45	V-packing (See 70-0291)	N/A Sep.	3	71	Flange	38-0047	1
20	Plug	39-0096	2	46	Packing Retainer	46-0871	3	72	Bolt	27-8888	4
21	O-ring	25-0387	2	47	O-ring	25-0501	3	73	Water Hose Connector	23-0001	1
22	Plug	39-0097	1	48	Low Pressure Seal (See 70-0291)	N/A Sep.	3	74	Gasket	19-0001	1
23	Bolt	27-8960	3	49	Retainer	46-0872	3		Valves (Includes 3 each 28, 43)	70-0290	
24	Lockwasher	29-0055	3	50	Oil Seal	26-0239	3		High Pressure Seals (Includes 3 each 45, 47-49)	70-0291	
25	Manifold	46-0880	1	51	O-ring	25-0502	1		Unloader Repair (Includes 2-19, 37)	70-0292	
26	Valve Cap	39-0087	3	52	Pump Housing	46-0873	1		Injector Repair (Includes 34-36)	70-0293	

GUN/WAND ASSEMBLY (16-0364)

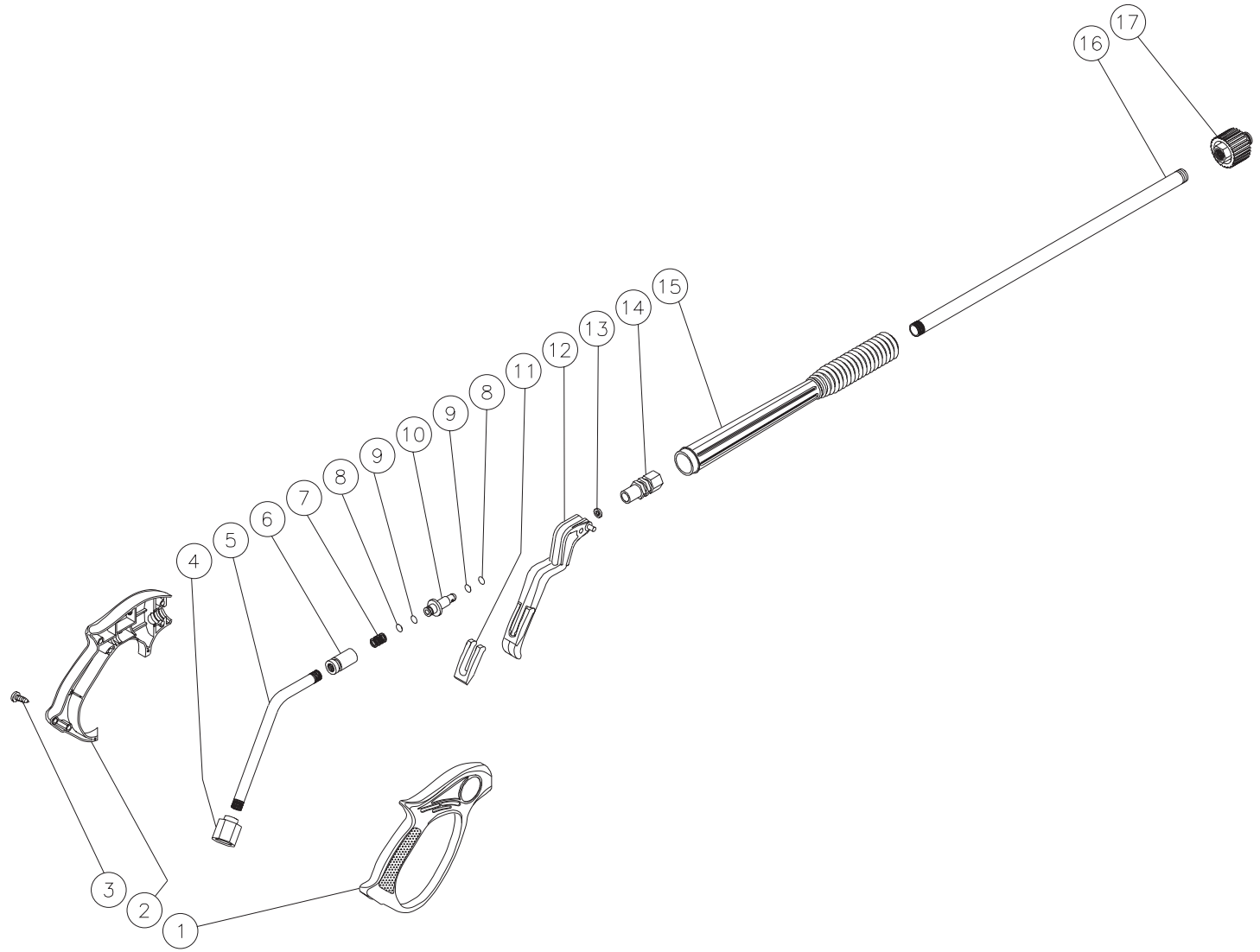

16-0364-103101-RD

GUN/WAND ASSEMBLY (16-0364)

REF. #	DESCRIPTION	PART #	QTY.	REF. #	DESCRIPTION	PART #	QTY.
1	Gun Body (Right Side)	16-0367	1	11	Trigger Lock	16-0372	1
2	Gun Body (Left Side)	16-0368	1	12	Trigger	16-0373	1
3	Screw	27-8862	6	13	Seat	26-0238	1
4	Adapter	23-0384	1	14	Brass Body Outlet	16-0374	1
5	Pipe (See 70-0287)	N/A Sep.	1	15	Gripping Area (Plastic)	16-0375	1
6	Brass Body Inlet	16-0370	1	16	Pipe	16-0376	1
7	Spring	49-0141	1	17	Screw Connect Coupling	16-0377	1
8	O-ring	25-0363	2		Inlet Kit (Includes 4-6)	70-0288	
9	Back-up Ring	25-0416	2		Shutter Valve Kit (Includes 7-10)	70-0289	
10	Valve	16-0371	1		Complete Gun/Wand Assembly (Inc. 1-17)	16-0364	

LANCE ASSEMBLY (16-0366)

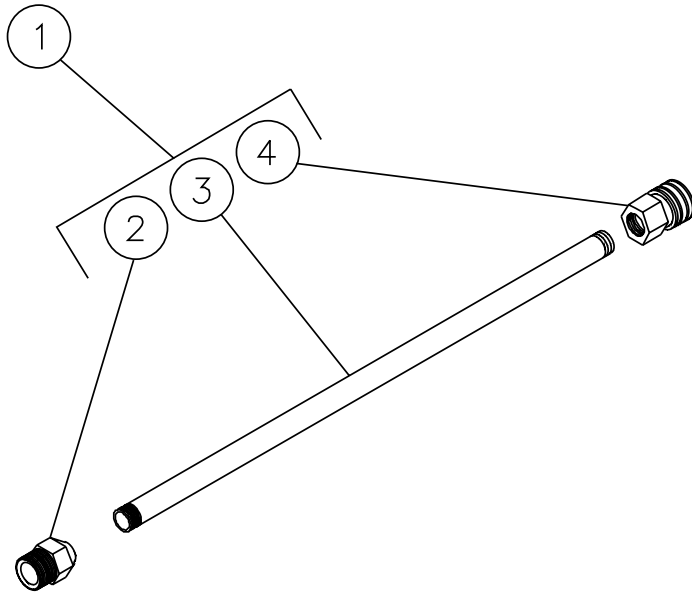

16-0366-102700-RD

LANCE ASSEMBLY (16-0366)			
REF. #	DESCRIPTION	PART #	QTY.
1	Complete Lance (Inc. 2-4)	16-0366	1
2	Coupling	16-0378	1
3	Pipe	16-0379	1
4	Quick Connect	17-0001	1

16-0366-102700-RD

NOTES

NOTES

NOTES

