

# P435B P455B Pumps

Triplex Ceramic  
Plunger Pump  
Operating Instructions/  
Repair and Service Manual

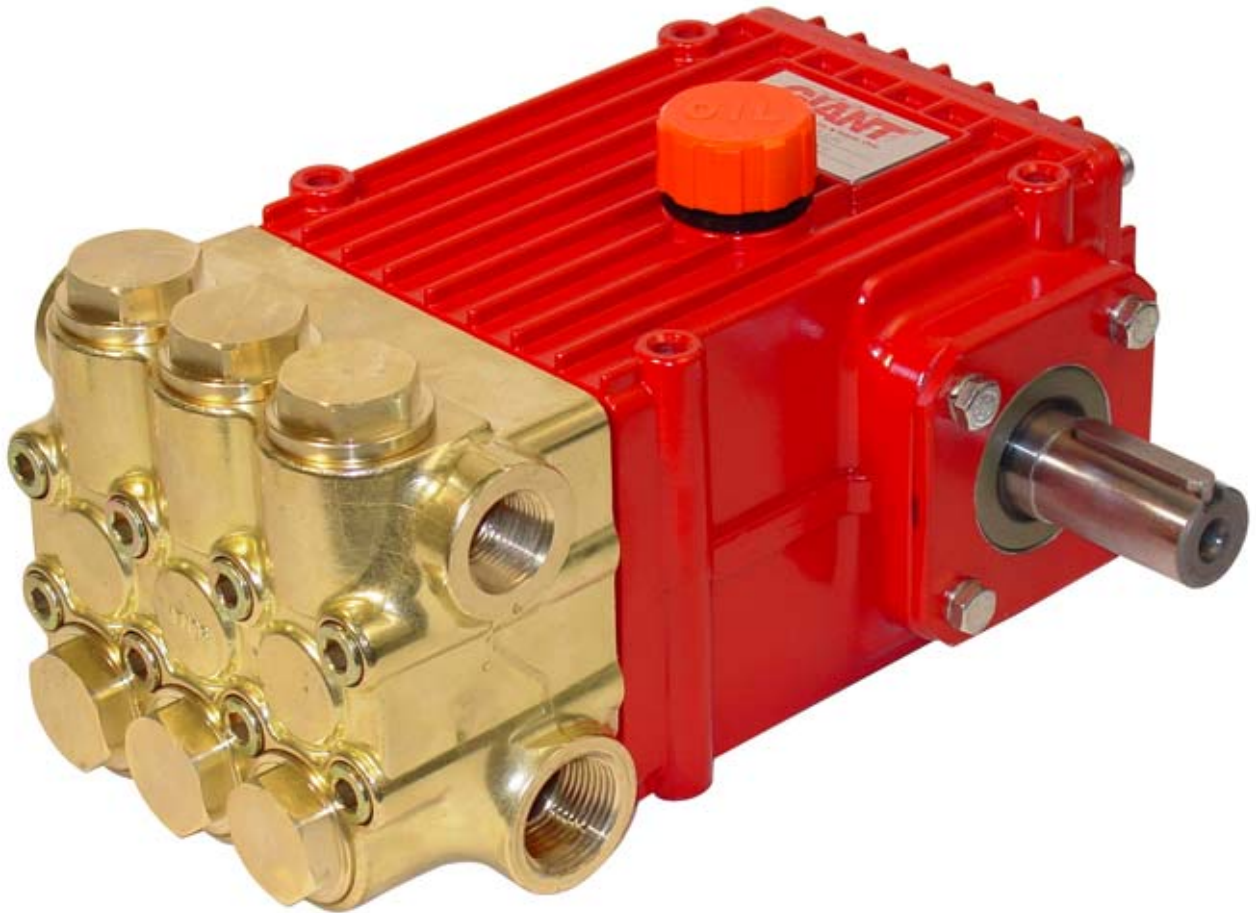

## Contents:

Installation Instructions:	page 2
Pump Specifications:	pages 3,6
Exploded View:	page 4
Parts List/Kits:	page 5
Repair InstructionsTorque Specs.:	pages 7-8
Trouble Shooting Chart:	page 9
Recommended Spare Parts List:	page 9
Dimensions:	page 10
Warranty Information	back page

# INSTALLATION INSTRUCTIONS

**Installation of the Giant Industries, Inc., pump is not a complicated procedure, but there are some basic steps common to all pumps. The following information is to be considered as a general outline for installation. If you have unique requirements, please contact Giant Industries, Inc. or your local distributor for assistance.**

1. The pump should be installed flat on a base to a maximum of a 15 degree angle of inclination to ensure optimum lubrication.
2. The inlet to the pump should be sized for the flow rate of the pump with no unnecessary restrictions that can cause cavitation. Teflon tape should be used to seal all joints. If pumps are to be operated at temperatures in excess of 160° F, it is important to insure a positive head to the pump to prevent cavitation.
3. The discharge plumbing from the pump should be properly sized to the flow rate to prevent line pressure loss to the work area. It is essential to provide a safety bypass valve between the pump and the work area to protect the pump from pressure spikes in the event of a blockage or the use of a shut-off gun.

4. Use of a dampener is necessary to minimize pulsation at drive elements, plumbing, connections, and other system areas. The use of a dampener with Giant Industries, Inc. pumps is optional, although recommended by Giant Industries, Inc. to further reduce system pulsation. Dampeners can also reduce the severity of pressure spikes that occur in systems using a shut-off gun. A dampener must be positioned downstream from the unloader.

5. Crankshaft rotation on Giant Industries, Inc. pumps should be made in the direction designated by the arrows on the pump crankcase. Reverse rotation may be safely achieved by following a few guidelines available upon request from Giant Industries, Inc. Required horsepower for system operation can be obtained from the charts on page 3.

6. Before beginning operation of your pumping system, remember: Check that the crankcase and seal areas have been properly lubricated per recommended schedules. Do not run the pump dry for extended periods of time. Cavitation will result in severe damage. Always remember to check that all plumbing valves are open and that pumped media can flow freely to the inlet of the pump.

Finally, remember that high pressure operation in a pump system has many advantages. But, if it is used carelessly and without regard to its potential hazard, it can cause serious injury.

## IMPORTANT OPERATING CONDITIONS

**Failure to comply with any of these conditions invalidates the warranty.**

1. Prior to initial operation, add oil to the crankcase so that oil level is between the two lines on the oil dipstick. **DO NOT OVERFILL.**

### **Use SAE 80-90W or Giant's p/n 01154**

Crankcase oil should be changed after the first 50 hours of operation, then at regular intervals of 500 hours or less depending on operating conditions.

2. Pump operation must not exceed rated pressure, volume, or RPM. A pressure relief device must be installed in the discharge of the system.

3. Acids, alkalines, or abrasive fluids cannot be pumped unless approval in writing is obtained before operation from Giant Industries, Inc.

4. Run the pump dry approximately 10 seconds to drain the water before exposure to freezing temperatures.

# Specifications Model P455B

	U.S. ....	(Metric)
Volume .....	Up to 5.5 GPM .....	(21.0 LPM)
Discharge Pressure Continuous .....	Up to 4,350 PSI .....	(300 bar)
Discharge Pressure Intermittant* .....	Up to 5,100 PSI* .....	(352 bar*)
Inlet Pressure .....	-4.35 to 145 PSI .....	(-.3 to 10 bar)
Stroke .....	0.787" .....	(20mm)
RPM .....	Up to 1450 RPM	
Plunger Diameter .....	0.708" .....	(18mm)
Temperature of Pumped Fluids .....	Up to 160 °F .....	(71 °C)
Inlet Ports .....	(2) 3/4" BSP	
Discharge Ports .....	(2) 1/2" BSP	
Shaft Rotation .....	Top of pulley towards manifold	
Crankshaft Diameter .....	1.102" .....	(28mm)
Key Width .....	.315" .....	(8mm)
Shaft Mounting .....	Either side <sup>1</sup>	
Weight .....	37 lbs. 6oz .....	(17.0 kg)
Crankcase Capacity .....	30 fl.oz. ....	(0.89 liters)
Volumetric Efficiency @ 1450 .....	(0.95)	
Mechanical Efficiency @ 1450 .....	(0.83)	

Consult the factory for special requirements that must be met if the pump is to operate beyond one or more of the limits specified above.

**NOTES:**

**In order to drive the pump from the side opposite the present shaft extension, simply remove the valve casing from the crankcase and rotate the pumps 180 degrees to the desired position. Be certain to rotate the seal case (item #20) as well, so that the weep holes are down at the six o'clock position. Exchange the oil fill and the oil drain plugs, also. Refer to the repair instructions as necessary for the proper assembly sequence.**

P455B HORSEPOWER REQUIREMENTS					
RPM	GPM	2000 PSI	3000 PSI	4350 PSI	5100 PSI*
920	3.5	4.8	7.2	10.5	12.3*
1050	4.0	5.5	8.3	12.0	14.1*
1185	4.5	6.2	9.3	13.5	15.8*
1315	5.0	6.9	10.3	15.0	17.6*
1450	5.5	7.6	11.4	16.5	19.3*

**HORSEPOWER RATINGS:**

The rating shown are the power requirements for the pump. Gas engine power outputs must be approximately twice the pump power requirements shown above.

We recommend a 1.15 service factor be specified when selecting an electric motor as the power source. To compute specific pump horsepower requirements, use the following formula:

$$HP = (GPM \times PSI) / 1450$$

**SPECIAL NOTE:**

The theoretical gallons per revolution (gal/rev) is 0.00379. To find specific outputs at various RPM, use the formula:

$$GPM = 0.00379 \times RPM$$

# EXPLODED VIEW - P455

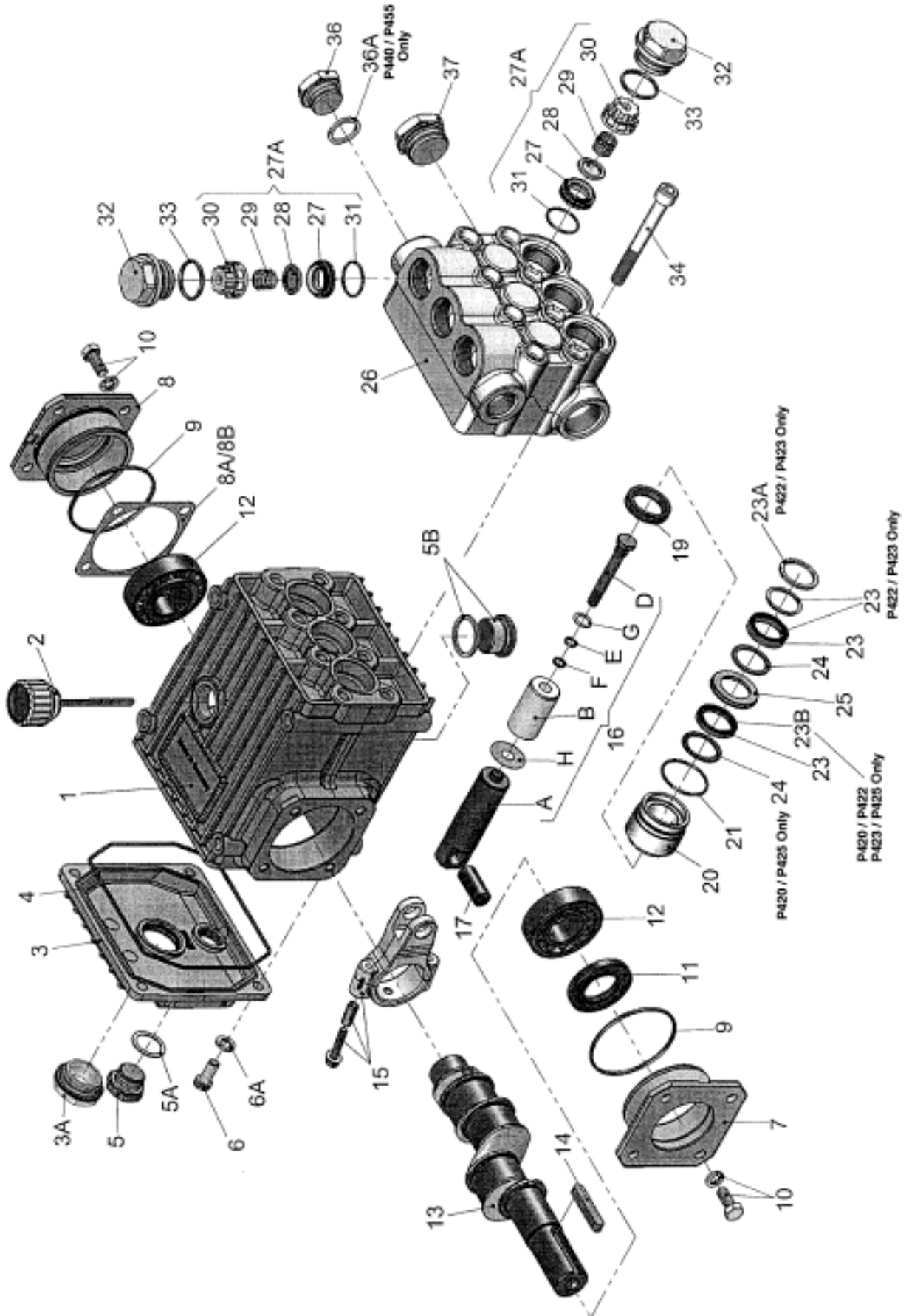

## P455 SPARE PARTS LIST

<u>ITEM</u>	<u>PART</u>	<u>DESCRIPTION</u>	<u>QTY.</u>	<u>ITEM</u>	<u>PART</u>	<u>DESCRIPTION</u>	<u>QTY.</u>
1	08377	Crankcase	1	16D	08399	Tensioning Screwing	3
2	08378	Oil Fill Plug with Gasket	1	16E	07023	O-Ring	3
3	06479	Crankcase cover	1	16F	07203	Backup Ring	3
3A	07186	Oil Sight Glass w/ Gasket	1	16G	07258	Copper Washer	3
4	08380	O-Ring	1	16H	06431	Oil Scraper	3
5	07109	Oil Drain Plug	1	17	06790	Crosshead Pin	3
5A	07182	Gasket for Oil Drain Plug	1	19	05444	Oil Seal	3
5B	08092	Plug with Gasket	1	20	05534	Seal Case	3
6	01010	Screw	4	21	07266	O-Ring	3
6A	01011-0400	Spring Washer	4	23	08477	V-Sleeve, 18mm	6
7	05290	Bearing Cover Open	1	24	07929	Pressure Ring	3
8	05291	Bearing Cover Closed	1	25	08402	Weep Return Ring	3
8A	05292	Shim	3	26	05574	Manifold - Brass	1
8B	05293	Shim (May not be present)	1	27A	05543	Valve Assy.	6
9	01016	O-Ring	2	27	05541	Valve Seat	6
10	07114	Screw with Washer	8	28	05542	Valve Plate	6
11	07459	Radial Shaft Seal	1	29	07906	Valve Spring	6
12	05350	Taper Roller Bearing	2	30	07907	Valve Spring Retainer	6
13	08475	Crankshaft (P435)	1	31	07770	O-Ring	6
13	08482	Crankshaft (P455)	1	32	05544	Plug	6
14	08091	Fitting Key	1	33	05545	O-Ring	6
15	08390	Connecting Rod Assembly	3	34	08484	Cap Screw	8
16	05484	Plunger Assy., 18mm (Items 16A-16H)	3	36	13434	Plug, 1/2" BSP	1
16A	05352	Plunger Base	3	36A	06272	O-Ring (P455 Only)	1
16B	08397	Plunger Pipe, 18mm	3	37	07703	Plug, G 3/4"	1

## P455B REPAIR KITS

### Plunger Packing Kit - # 09643

<u>Item</u>	<u>Part</u>	<u>#Description</u>	<u>Qty</u>
21	07266	O-Ring	3
23	08477	V-Sleeve	6
24	07929	Pressure Ring	3

### Valve Assembly Kit - # 09644

<u>Item</u>	<u>Part</u>	<u>#Description</u>	<u>Qty</u>
27A	05543	Valve Assembly, Complete	6
33	05545	O-Ring	6

### Oil Seal Kit - #09641

<u>Item</u>	<u>Part #</u>	<u>Description</u>	<u>Qty</u>
19	05444	Oil Seal	3

# Specifications Model P435B

	U.S. .... (Metric)
Volume .....	Up to 6.6 GPM ..... (25.0 LPM)
Discharge Pressure Continuous .....	Up to 3,625 PSI ..... (250 bar)
Inlet Pressure .....	-4.35 to 145 PSI ..... (-.3 to 10 bar)
Stroke .....	0.94" ..... (24mm)
RPM .....	Up to 1450 RPM
Plunger Diameter .....	0.708" ..... (18mm)
Temperature of Pumped Fluids .....	Up to 160 °F ..... (71 °C)
Inlet Ports .....	(2) 3/4" BSP
Discharge Ports .....	(2) 1/2" BSP
Shaft Rotation .....	Top of pulley towards manifold
Crankshaft Diameter .....	1.102" ..... (28mm)
Key Width .....	.315" ..... (8mm)
Shaft Mounting .....	Either side <sup>1</sup>
Weight .....	37 lbs. 6oz ..... (17.0 kg)
Crankcase Capacity .....	30 fl.oz. .... (0.89 liters)
Volumetric Efficiency @ 1450 .....	(0.95)
Mechanical Efficiency @ 1450 .....	(0.83)

Consult the factory for special requirements that must be met if the pump is to operate beyond one or more of the limits specified above.

**NOTES:**

**In order to drive the pump from the side opposite the present shaft extension, simply remove the valve casing from the crankcase and rotate the pumps 180 degrees to the desired position. Be certain to rotate the seal case (item #20) as well, so that the weep holes are down at the six o'clock position. Exchange the oil fill and the oil drain plugs, also. Refer to the repair instructions as necessary for the proper assembly sequence.**

<b>P435B HORSEPOWER REQUIREMENTS</b>					
<b>RPM</b>	<b>GPM</b>	<b>2000 PSI</b>	<b>2500 PSI</b>	<b>3000 PSI</b>	<b>3625 PSI</b>
920	4.2	5.8	7.2	8.7	10.5
1050	4.8	6.6	8.3	9.9	12.0
1185	5.4	7.4	9.3	11.2	13.5
1315	6.0	8.3	10.3	12.4	15.0
1450	6.6	9.1	11.4	13.7	16.5

**HORSEPOWER RATINGS:**

The rating shown are the power requirements for the pump. Gas engine power outputs must be approximately twice the pump power requirements shown above.

We recommend a 1.15 service factor be specified when selecting an electric motor as the power source. To compute specific pump horsepower requirements, use the following formula:

$$HP = (GPM \times PSI) / 1450$$

**SPECIAL NOTE:**

The theoretical gallons per revolution (gal/rev) is 0.00455. To find specific outputs at various RPM, use the formula:  
 $GPM = 0.00455 \times RPM$

## REPAIR INSTRUCTIONS - P455

**Note:** Always take time to lubricate all metal and nonmetal parts with a light film of oil before reassembly. This step will ensure proper fit, at the same time protecting the pump nonmetal parts (i.e., the elastomers) from cutting and scoring.

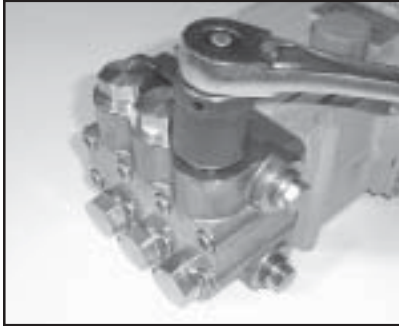

- 1) With a socket wrench, remove the three discharge valve plugs and three inlet valve plugs (32). Inspect the o-ring (33) for wear and replace if damaged.

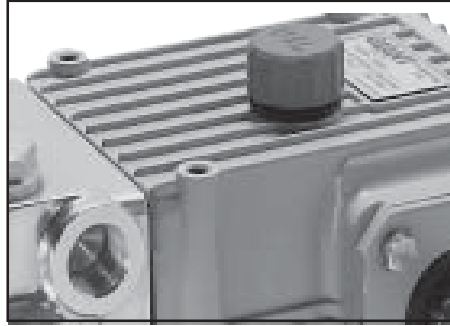

- 2) Using needle nose pliers, remove the inlet and discharge valve assemblies (27A). Note: It may become necessary to remove the valve seat (27) from the valve casing using a slidehammer.



- 3) By inserting a small screw driver between the valve seat (27) and the valve spring retainer (30), the valve assembly can be separated.



- 4) Remove the o-ring (31). Inspect all parts for wear and replace as necessary. Apply one drop of loctite 243 to the valve plugs (32) and tighten to 125 ft. lbs.

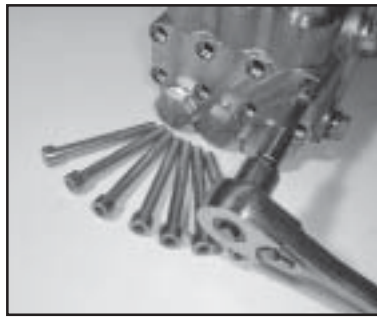

- 5) Use a 8mm allen wrench to remove the 8 socket head cap screws (34). Carefully slide the valve casing (26) out over the plungers.



- 6) Remove seal adaptors (20) and weep return rings (25) from the valve casing.



- 7) Remove the pressure rings (24) and v-sleeves (23) Note: P422 & P423 pumps have a support ring) from the valve casing (26).



- 8) Remove the weep grooved seal (23 or 23B) together with pressure ring (24 \_ P420 and P425 only) out of the seal adaptor (20). Check O-rings (21).

**IMPORTANT!** The grooved seal (23) or respectively grooved seal pack (23A) on the high-pressure side is to be fitted carefully into the valve casing (26) using a screwdriver. Under no circumstances must the seal surface in the valve casing or the seal lip be damaged.

## REPAIR INSTRUCTIONS - P455

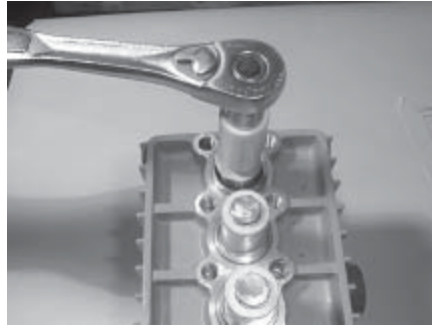
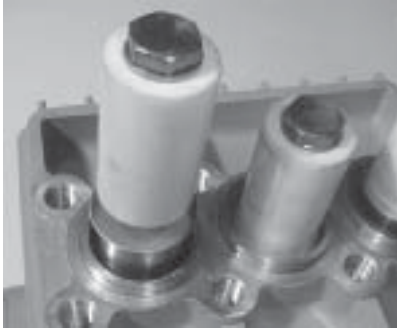

**IMPORTANT!** Care must be taken that glue does not get between the plunger pipe (16B) and centring sleeve (16C). The plunger pipe should not be strained by eccentric tightening of the tension screw or through damage to front surface of plunger, otherwise it is liable to fracture.

- 9) Check surfaces of plunger (16). Damaged surfaces cause accelerated seal wear. Deposits of all kinds must be removed from the plungers.

**IMPORTANT!** Plunger surfaces are not to be damaged. If there are lime deposits in the pump, care must be taken that the drip-return bore in parts (25) and (26) ensure trouble-free drip-return.

- 10) If the plunger pipe (16B) is worn, remove tension screw (16D) and remove along with plunger pipe (16B). Check and clean plunger surface (16A), check oil scraper (16H). Cover thread of tension screw (16D) with a thin film of Loctite and tighten carefully to 26 ft.-lbs. (35NM).

- 11) After installation of high pressure seals (23 - Note: P422 and P423, also have a support ring), place seal adaptor (20) with weep seals & pressure ring installed, weep return ring (25) and high pressure weep return ring (24) over plungers. Slide valve casing over plungers and seat firmly. Replace the 8 socket head cap screws (34) and tighten to 35 ft.-lbs. in a crossing pattern (as shown to the right).

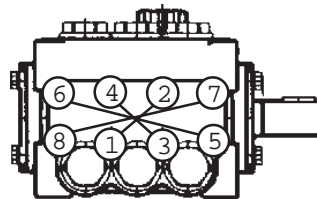

## TORQUE SPECIFICATIONS - P455

<u>Position</u>	<u>Item#</u>	<u>Description</u>	<u>U.S</u>	<u>Metric</u>
15	08390	Screw with Washer	216 in.-lbs.	24.4 N-M
16D	08399	Tension Screw	240 in.-lbs.	27.1 N-M
32	05544	Plug (P455)	125 ft.-lbs.	169.4 N-M
34	08484	Cap Screw	35 ft.-lbs.	47.5 N-M

**Contact Giant Industries for service school information. Phone: (419) 531-4600**



## PUMP SYSTEM MALFUNCTION

<u>MALFUNCTION</u>	<u>CAUSE</u>	<u>REMEDY</u>
The Pressure and/ or the Delivery Drops	Worn packing seals Broken valve spring Belt slippage Worn or Damaged nozzle Fouled discharge valve Fouled inlet strainer Worn or Damaged hose Worn or Plugged relief valve on pump Cavitation pump for restrictions Unloader	Replace packing seals Replace spring Tighten or Replace belt Replace nozzle Clean valve assembly Clean strainer Repair/Replace hose Clean, Reset, and Replace worn parts Check suction lines on inlet of  Check for proper operation
Water in crankcase	High humidity Worn seals	Reduce oil change interval Replace seals
Noisy Operation	Worn bearings  Cavitation	Replace bearings, Refill crankcase oil with recommended lubricant Check inlet lines for restrictions and/or proper sizing
Rough/Pulsating Operation with Pressure Drop	Worn packing Inlet restriction  Accumulator pressure Unloader Cavitation	Replace packing Check system for stoppage, air leaks, correctly sized inlet plumbing to pump Recharge/Replace accumulator Check for proper operation Check inlet lines for restrictions and/or proper size
Pump Pressure as Rated, Pressure Drop at Gun	Restricted discharge plumbing	Re-size discharge plumbing to Flow Rate of Pump
Excessive Leakage	Worn plungers Worn packing/seals Excessive vacuum Cracked plungers Inlet pressure too high	Replace plungers Adjust or Replace packing seals Reduce suction vacuum Replace plungers Reduce inlet pressure
High Crankcase ture	Wrong Grade of oil Improper amount of oil in crankcase	Giant oil is recommended Tempera- Adjust oil level to proper amount

### Preventative Maintenance Check-List & Recommended Spare Parts List

CHECK	DAILY	WEEKLY	50HRS	EVERY 500HRS	EVERY 1500HRS	EVERY 3000HRS
Oil Level/Quality	X					
Oil Leaks	X					
Water Leaks	X					
Belts, Pulley		X				
Plumbing					X	
<b>Recommended Spare Parts</b>						
Oil Change (1 Gallon) p/n 1154			X	X		
Seal Spare Parts (1 kit/pump) (See page 5 for kit list)					X	
Oil Seal Kit (1 kit/pump) (See page 5 for kit list)					X	
Valve Spare Parts (1 kit/pump) (See page 5 for kit list)						X

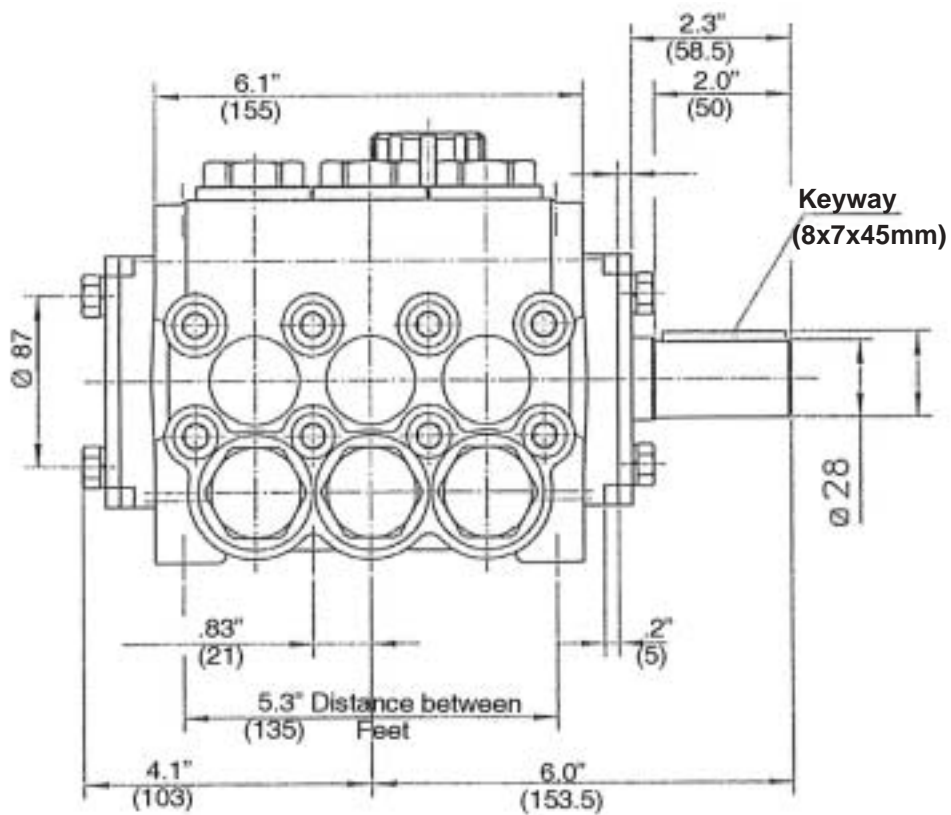
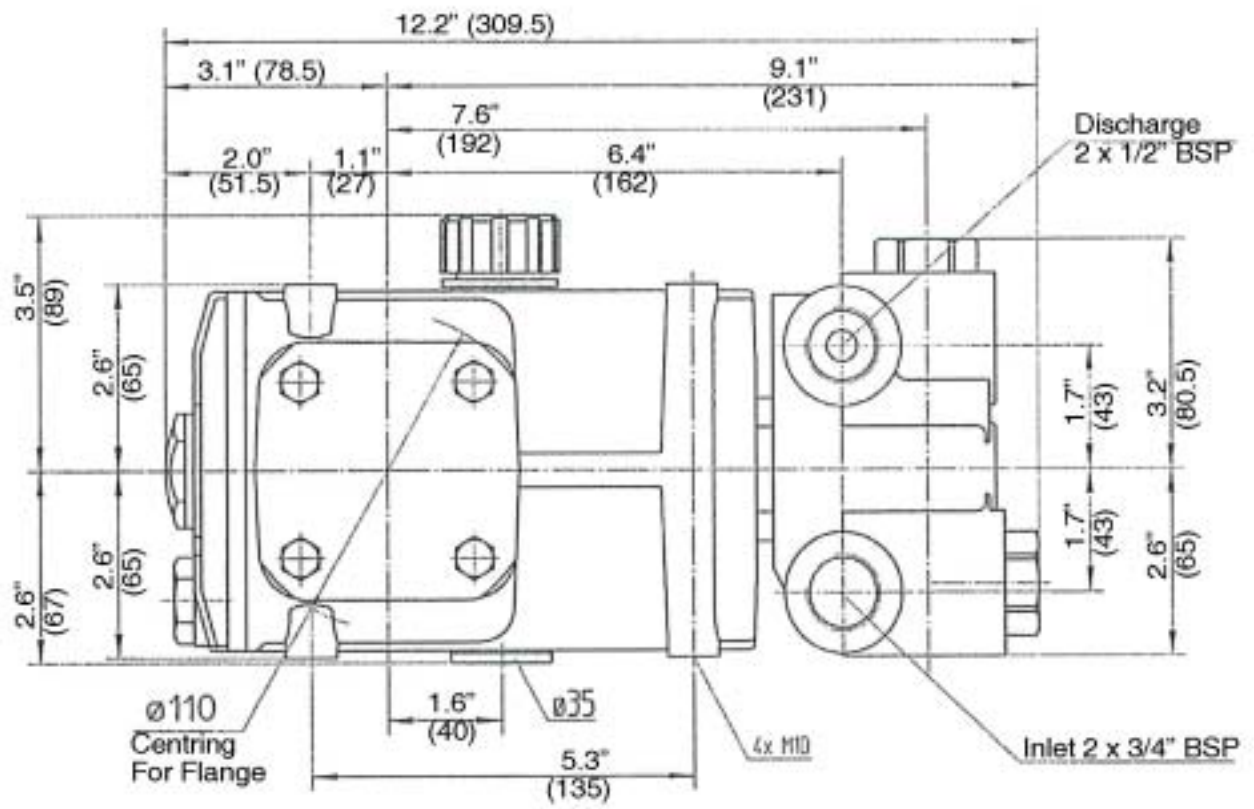

# NOTES

## GIANT INDUSTRIES LIMITED WARRANTY

Giant Industries, Inc. pumps and accessories are warranted by the manufacturer to be free from defects in workmanship and material as follows:

1. For portable pressure washers and self-service car wash applications, the discharge manifolds will never fail, period. If they ever fail, we will replace them free of charge. Our other pump parts, used in portable pressure washers and in car wash applications, are warranted for five years from the date of shipment for all pumps used in NON-SALINE, clean water applications.
2. One (1) year from the date of shipment for all other Giant industrial and consumer pumps.
3. Six (6) months from the date of shipment for all rebuilt pumps.
4. Ninety (90) days from the date of shipment for all Giant accessories.

This warranty is limited to repair or replacement of pumps and accessories of which the manufacturer's evaluation shows were defective at the time of shipment by the manufacturer.

The following items are NOT covered or will void the warranty:

1. Defects caused by negligence or fault of the buyer or third party.
2. Normal wear and tear to standard wear parts.
3. Use of repair parts other than those manufactured or authorized by Giant.
4. Improper use of the product as a component part.
5. Changes or modifications made by the customer or third party.
6. The operation of pumps and or accessories exceeding the specifications set forth in the Operations Manuals provided by Giant Industries, Inc.

Liability under this warranty is on all non-wear parts and limited to the replacement or repair of those products returned freight prepaid to Giant Industries which are deemed to be defective due to workmanship or failure of material. A Returned Goods Authorization (R.G.A.) number and completed warranty evaluation form is required prior to the return to Giant Industries of all products under warranty consideration. Call (419)-531-4600 or fax (419)-531-6836 to obtain an R.G.A. number.

Repair or replacement of defective products as provided is the sole and exclusive remedy provided hereunder and the MANUFACTURER SHALL NOT BE LIABLE FOR FURTHER LOSS, DAMAGES, OR EXPENSES, INCLUDING INCIDENTAL AND CONSEQUENTIAL DAMAGES DIRECTLY OR INDIRECTLY ARISING FROM THE SALE OR USE OF THIS PRODUCT.

THE LIMITED WARRANTY SET FORTH HEREIN IS IN LIEU OF ALL OTHER WARRANTIES OR REPRESENTATION, EXPRESS OR IMPLIED, INCLUDING WITHOUT LIMITATION ANY WARRANTIES OR MERCHANTABILITY OR FITNESS FOR A PARTICULAR PURPOSE AND ALL SUCH WARRANTIES ARE HEREBY DISCLAIMED AND EXCLUDED BY THE MANUFACTURER.



**GIANT INDUSTRIES, INC.**, 900 N. Westwood Ave.,  
P.O. Box 3187, Toledo, Ohio 43607  
PHONE (419) 531-4600, FAX (419) 531-6836,  
[www.giantpumps.com](http://www.giantpumps.com)  
© Copyright 2009 Giant Industries, Inc.