

THE **JOB PRO**[®] by **Mi-T-M**[®]

8650 Enterprise Drive, Peosta IA 52068
563-556-7484 / Fax 563-556-1235
www.mitm.com

PARTS LIST FOR ***JP-3004-2MHB*** ***JP-3004-2MVB***

Engine Oil Grade:

Honda:

SAE10W-30

Vanguard:

Above 40°F = SAE30

Below 40°F = SAE10W-30

Engine Oil Capacity:

Honda:

37 oz.

Vanguard:

51 oz.

Pump Oil Grade:

75W90 Synthetic

Pump Oil Capacity:

14 oz.

Nozzle Size:

4.0

This Parts Listing has been compiled for your benefit. You can be assured your Mi-T-M Cold Water Pressure Washer was constructed and designed with quality and performance in mind using over 25 years experience in the pressure washer business. Each component has been rigorously tested to insure the highest level of acceptance.

The contents of this Parts Listing are based on the latest product information available at the time of publication. Mi-T-M reserves the right to make changes in price, color, materials, equipment, specifications or models at any time without notice.

WARNING

THIS IS A PROFESSIONAL HIGH PRESSURE, COLD WATER PRESSURE WASHER. CAUTION SHOULD BE OBSERVED WHEN USING OR REPAIRING THIS UNIT! READ AND FOLLOW THE SAFETY WARNINGS LISTED BELOW BEFORE ATTEMPTING ANY REPAIRS ON THIS PRESSURE WASHER!

SAFETY WARNINGS

1. NEVER alter or modify the equipment. Be sure any accessory items and system components being used will withstand the pressure developed. Use only genuine Mi-T-M parts for repair of your pressure washer. Failure to do so can cause hazardous operating conditions and will VOID warranty.
2. NEVER make adjustments on machinery while the unit is connected to the engine without first removing the ignition cable from the spark plug. Turning over the machinery by hand during adjustment or cleaning might start the engine and machinery with it, causing serious injury to the operator.
3. Know how to stop and bleed pressures quickly. Be thoroughly familiar with controls.
4. Before servicing the unit, turn unit off, relieve the water pressure and allow the unit to cool down. Do not make repairs while the unit is running. Service in a clean, dry, flat area. Block the wheels to prevent the unit from moving. Be especially careful to properly dispose of any flammable materials.
5. After testing the machine, DO NOT leave the pressurized unit unattended. Shut off the unit and release trapped pressure before leaving.

Table of Contents

SPECIFICATIONS	3
FRAME ASSEMBLY FOR JP-3004-2MHB/VB	4
PUMP ASSEMBLY (3-0264)	6
UNLOADER ASSEMBLY (8-0563)	8
GUN ASSEMBLY (16-0001)	10

SPECIFICATIONS

MODEL NUMBER	JP-3004-2MHB	JP-3004-2MVB
Operating Pressure (PSI/Bar):	3000 / 206.8	
High Pressure Nozzle:	4.0	
Water Volume (GPM/lpm):	3.9 / 14.7	
Engine:	Honda	Vanguard
Horsepower	13.0	
Engine Type	4 Stroke, Overhead Valve, Single Cylinder	
Oil Type	SAE 10W-30	Above 40°F = SAE30 Below 40°F = SAE10W-30
Oil Capacity (oz./liters)	37 / 1.1	51 / 1.5
Low Oil Protection	Oil Alert™	Oil Guard™
Fuel Type	Unleaded Gasoline 86 Octane Minimum	
Fuel Capacity (gallon/ liters)	1.7 / 6.5	2.0 / 7.9
Starting	Recoil	
Maximum No Load RPM	3600 (+/- 100) RPM	
Pump:	Direct Driven, Oil Bath, Triplex Piston	
Oil Type	75W90 Synthetic	
Oil Capacity (oz./liters)	14 / .41	
Plungers	Ceramic	
Manifold	Forged Brass	
Valves	Stainless Steel	
Unloader	Adjustable	
Thermal Relief Valve	Relieves heated water during unloader bypass stage	
Detergent Injector	Adjustable low pressure down stream from pump	
Unit Net Weight (lbs/Kg)	136 / 62	140 / 64
Unit Shipping Weight (lbs/Kg)	186 / 85	190 / 87
Unit Net Dimension (in/cm)	35L x 22.5W x 26H / 89L x 57W x 66H	
Unit Shipping Dimension (in/cm)	39.5H x 25W x 31.5H / 100.5L x 63.5W x 80H	

FRAME ASSEMBLY FOR JP-3004-2MHB/VB

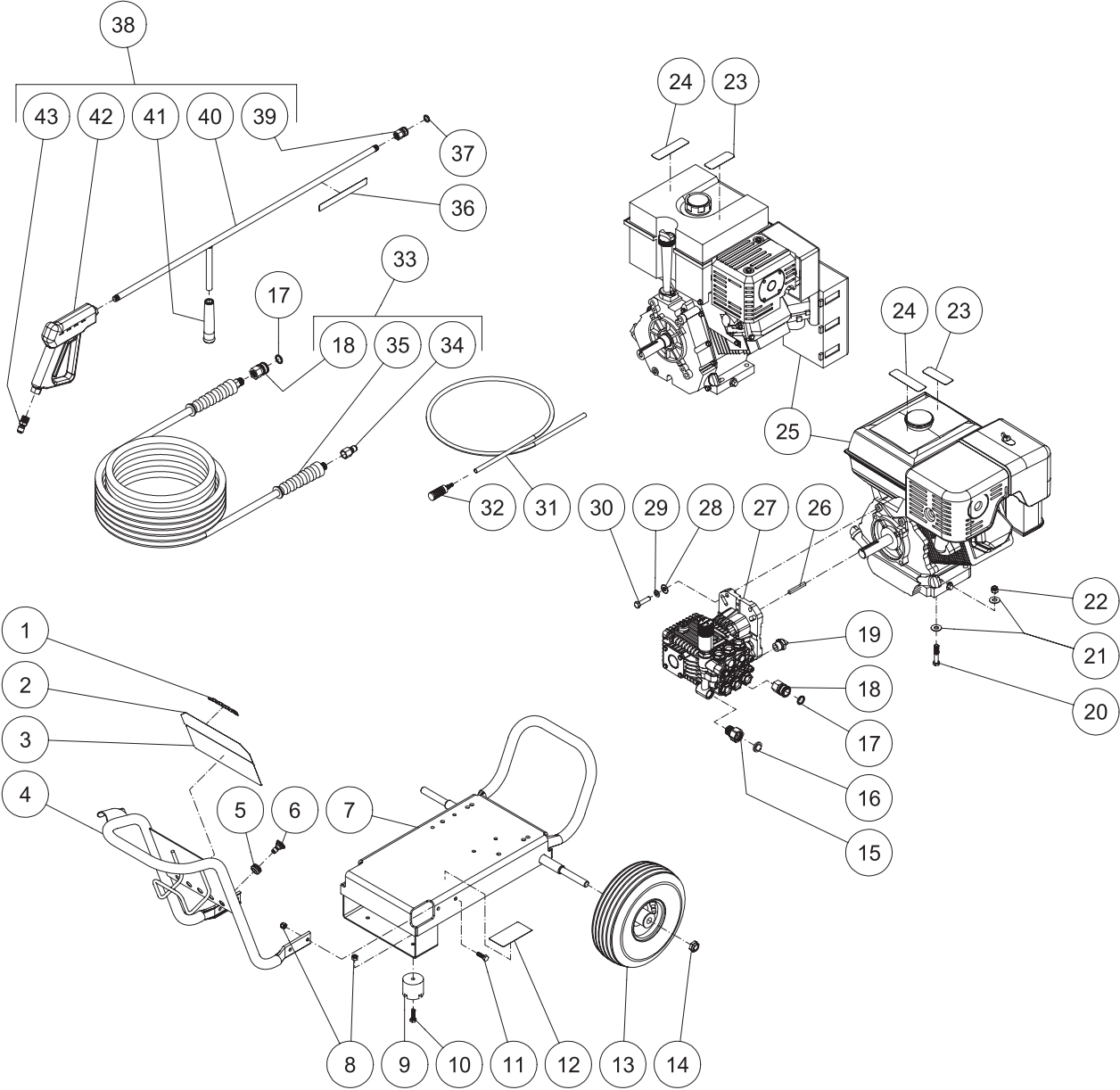

NOTE:

FRAME ASSEMBLY FOR JP-3004-2MHB/VB							
REF. #	DESCRIPTION	PART #	QTY.	REF. #	DESCRIPTION	PART #	QTY.
1	Decal- 3000 Die Cut	34-0775	1	22	Locknut	30-0159	4
2	Decal- Job Pro Placard	34-0778	1	23	Decal- Caution: Risk of Fire (See 34-9014)	N/A Sep.	1
3	Decal- Warning/Caution/Operating (See 34-9014)	N/A Sep.	1	24	Decal- Warning: Risk of Burns (See 34-9014)	N/A Sep.	1
4	Front Handle Assembly	7-0194A01	1	25	Engine- 13.0 H.P. Honda (JP-3004-2MHB)	1-0086	1
5	Grommet	33-0001	5	-	Engine- 13.0 H.P. Vanguard (JP-3004-2MVB)	1-0090	1
6	Nozzle- 0004.5	18-0033	1	26	Key	43-0078	1
-	Nozzle- 1504.5	18-0039	1	27	Pump	3-0264	1
-	Nozzle- 2504.5	18-0060	1	28	Washer	28-0022	4
-	Nozzle- 6540	18-0148	1	29	Lockwasher	29-0008	4
7	Frame	5-0254A01	1	30	Bolt	27-0119	4
8	Locknut	30-0157	2	31	Detergent Hose *(Four Feet Required)	15-0021	1
9	Isolator	14-0008	2	32	Detergent Strainer	19-0050	1
10	Bolt	27-0068	2	33	Pressure Hose Assembly (Inc. 18, 34-35)	851-0007	1
11	Bolt	27-0067	4	34	Quick Connect Plug	17-0006	1
12	Decal- Data Plate	N/A	1	35	Pressure Hose	15-0003	1
13	Wheel	14-0017	2	36	Decal- Warning: Risk of Injection (See 34-9014)	N/A Sep.	1
14	Jam Nut	30-0117	2	37	O-ring (Replacement Only)	25-0122	-
15	Garden Hose Swivel	23-0445	1	38	Gun/Wand Assembly (Inc. 39-43)	851-0095	1
16	Filter	19-0001	1	39	Quick Connect Plug	17-0001	1
17	O-ring (Replacement Only)	25-0123	-	40	Wand w/ Handle	16-0418	1
18	Quick Connect Socket	17-0004	2	41	Grip Handle	7-0002	1
19	Thermal Relief Valve	22-0005	1	42	Gun	16-0001	1
20	Bolt	27-0121	4	43	Quick Connect Plug	17-0005	1
21	Washer	28-0023	8		Safety Decal Kit (Inc. 3, 23-24, 36)	34-9014	

*Must Order in One Foot Lengths

PUMP ASSEMBLY (3-0264)

TORQUE SPECS	
POSITION	FT-LBS/N-M
13	14.7/20
15	14.7/20
16	73.7/100
21	29.4/40
22	29.4/40
39	7.3/10
43	7.3/10
53	11.0/15
60	7.3/10

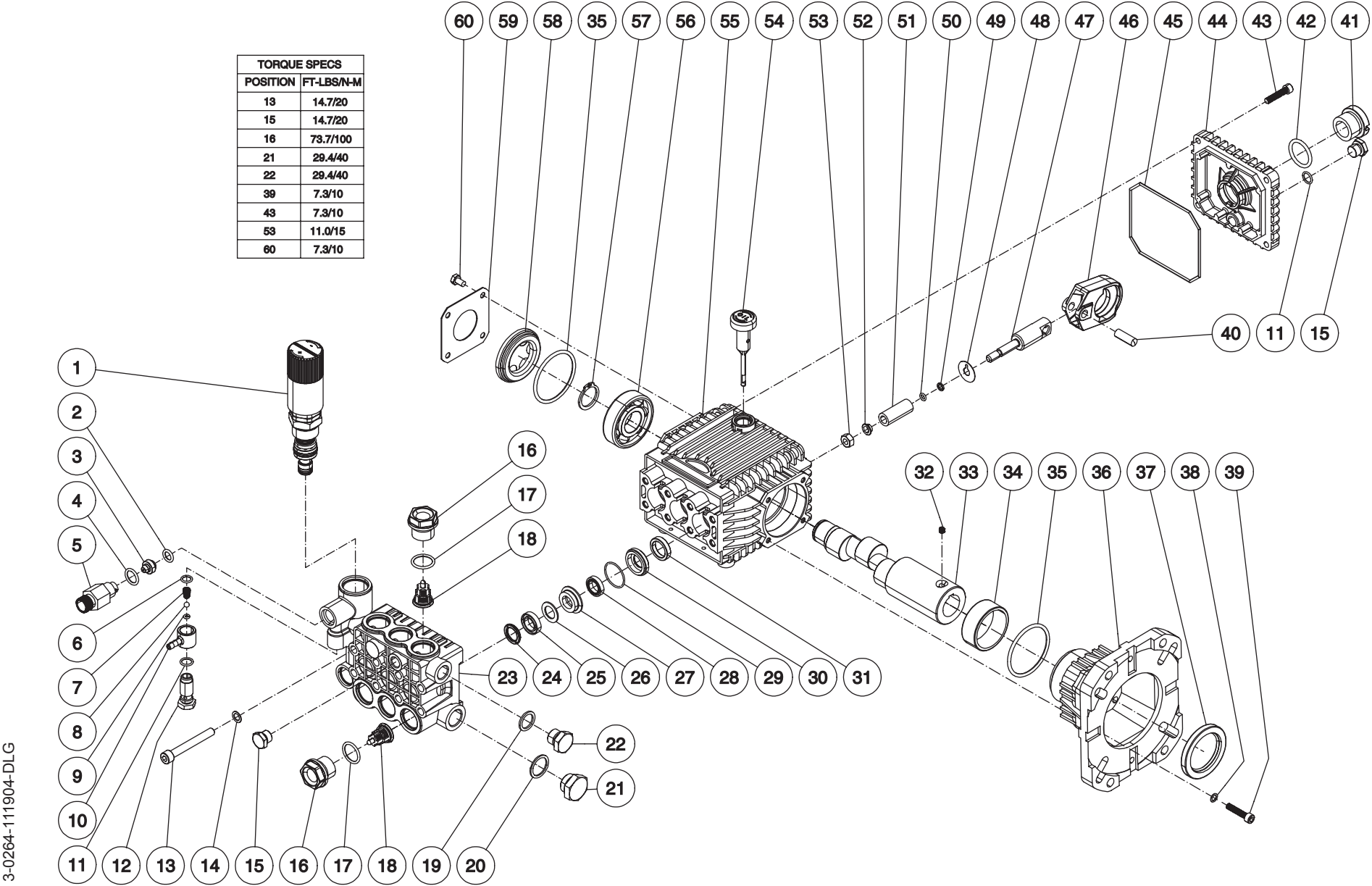

3-0264-111904-DLG

PUMP ASSEMBLY (3-0264)

REF. #	DESCRIPTION	PART #	QTY.	REF. #	DESCRIPTION	PART #	QTY.	REF. #	DESCRIPTION	PART #	QTY.
1	Unloader Assembly	8-0563	1	23	Manifold	46-1159	1	45	O-ring	25-0317	1
2	O-ring	25-0050	1	24	Head Ring (See 70-0415)	N/A Sep.	3	46	Connecting Rod	46-1160	3
3	Orifice	8-0121	1	25	Packing (See 70-0415)	N/A Sep.	3	47	Plunger Guide	46-1165	3
4	O-ring	25-0051	1	26	Restop (See 70-0415)	N/A Sep.	3	48	Washer	28-1049	3
5	Nipple	46-0788	1	27	High Pressure Retainer (See 70-0415)	N/A Sep.	3	49	Anti-Extrusion Ring	25-0143	3
6	O-ring	25-0120	1	28	Low Pressure Seal (See 70-0415)	N/A Sep.	3	50	O-ring	25-0502	3
7	Spring	49-0020	1	29	O-ring (See 70-0415)	N/A Sep.	3	51	Plunger	46-0228	3
8	Ball	50-0012	1	30	Low Pressure Seal Retainer (See 70-0415)	N/A Sep.	3	52	Washer	46-0166	3
9	O-ring	25-0045	1	31	Oil Seal (See 70-0414)	N/A Sep.	3	53	Nut	46-0168	3
10	Hose Barb Pump	46-0789	1	32	Screw	27-8886	1	54	Dipstick	46-0143	1
11	O-ring	25-0310	2	33	Crankshaft	46-1168	1	55	Crankcase	46-1166	1
12	Injector Valve Seat	8-0174	1	34	Bearing Needle	48-0040	1	56	Ball Bearing	48-0011	1
13	Bolt	27-9576	8	35	O-ring	25-0060	2	57	Ring	46-0104	1
14	Lockwasher	29-0154	8	36	Flange	38-0038	1	58	Oil Level Indicator	46-0574	1
15	Plug	39-0017	2	37	Oil Seal	26-0181	1	59	Oil Level Retainer	46-0084	1
16	Valve Plug	39-0071	6	38	Lockwasher	29-0153	4	60	Screw	27-8000	4
17	O-ring	25-0012	6	39	Screw	27-8404	4		Oil Seal Kit (Inc. 3 each 31)	70-0414	
18	Valve Assembly (See 70-0028)	N/A Sep.	6	40	Pin	46-1162	3		Valve Kit (Inc. 6 each 18)	70-0028	
19	Washer	28-0600	1	41	Sight Glass	46-1163	1		Packing Assembly (Inc. 24-30)	70-0415	
20	Washer	28-1038	1	42	O-ring	25-0059	1		Injector Repair Kit (Inc. 6-12)	70-0416	
21	Plug	39-0019	1	43	Screw	27-8401	4				
22	Plug	39-0018	1	44	Crankcase Cover	46-1164	1				

UNLOADER ASSEMBLY (8-0563)

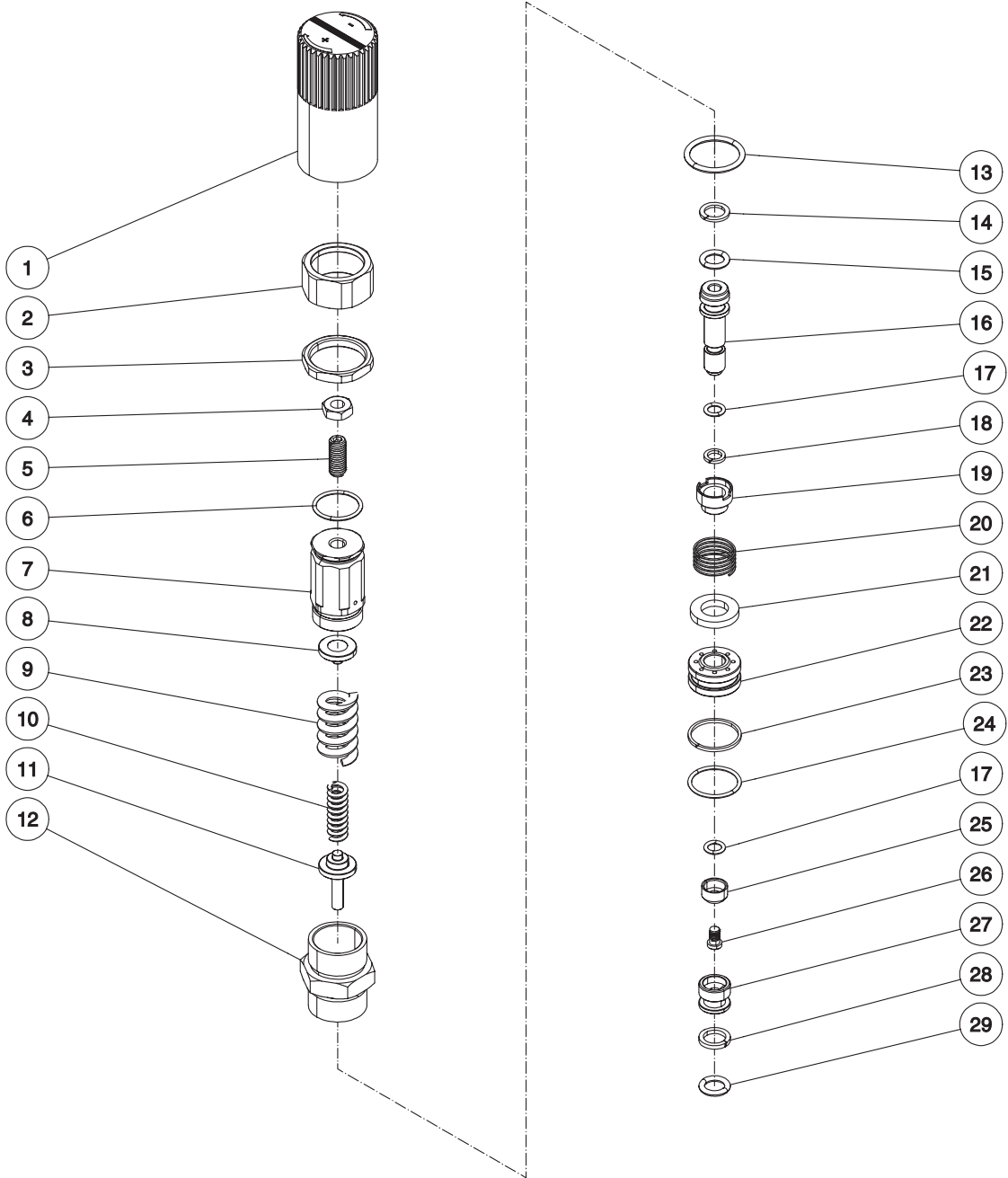

UNLOADER ASSEMBLY (8-0563)

REF. #	DESCRIPTION	PART #	QTY.	REF. #	DESCRIPTION	PART #	QTY.
1	Adjusting Knob	7-0071	1	16	Piston Valve	8-0556	1
2	Lock Sleeve	30-9522	1	17	O-ring	25-0167	2
3	Locknut	30-9523	1	18	Back-up Ring	8-0287	1
4	Hex Nut	8-0293	1	19	Spacer	8-0557	1
5	Set Screw	27-9570	1	20	Spring	8-0558	1
6	O-ring	25-0129	1	21	Non-Return Valve	8-0559	1
7	Adjustment Barrel	8-0292	1	22	Valve Guide	8-0560	1
8	Cap	39-0043	1	23	Back-up Ring (See 70-0394)	N/A Sep.	1
9	Spring	49-0156	1	24	O-ring	25-0101	1
10	Spring	49-0161	1	25	Unloader Valve	22-0130	1
11	Lower Spring Guide	8-0555	1	26	Screw	8-0285	1
12	Bushing	8-0562	1	27	Valve Seat	8-0561	1
13	O-ring	25-0139	1	28	Anti Extrusion Ring	8-0284	1
14	Back-up Ring (See 70-0394)	N/A Sep.	1	29	O-ring	25-0050	1
15	O-ring	25-0390	1		Unloader Repair Kit (Inc. 14-29)	70-0394	

GUN ASSEMBLY (16-0001)

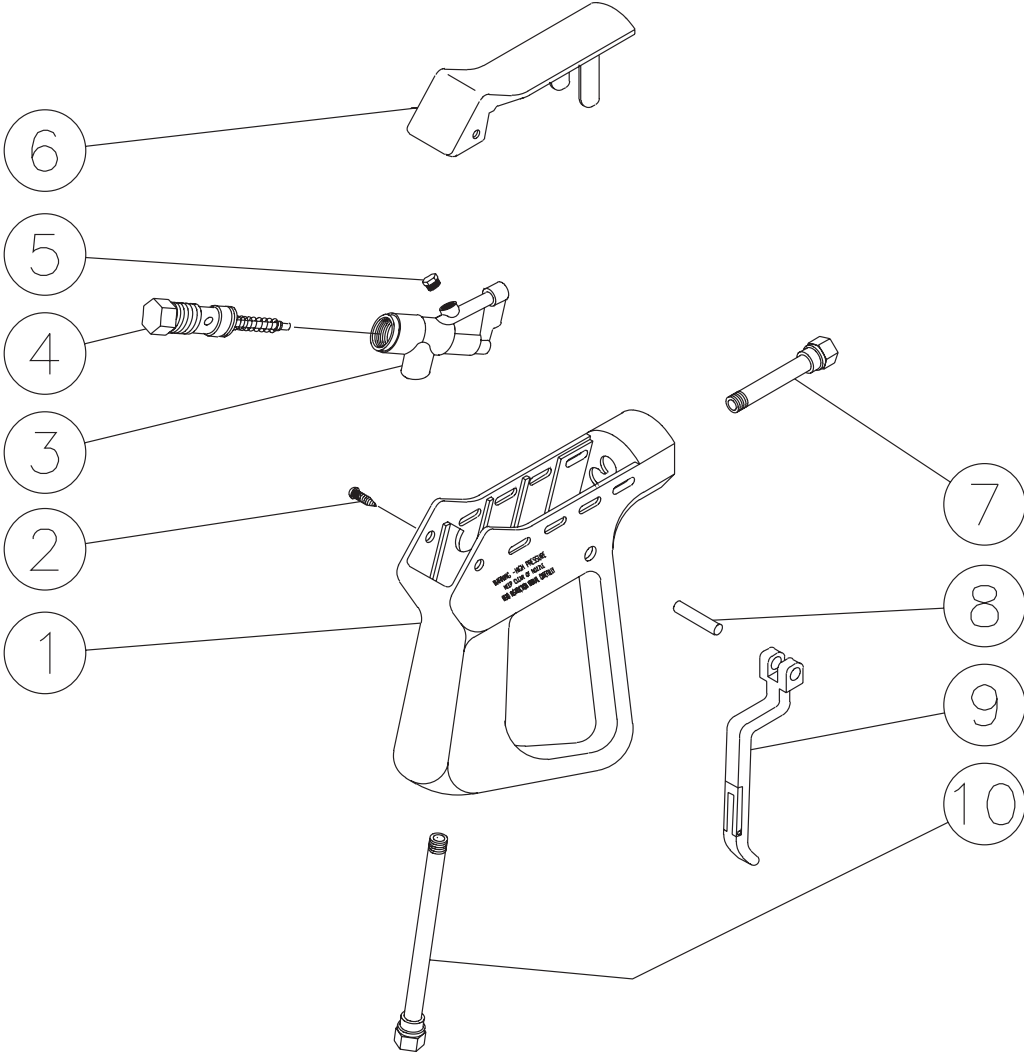

16-0001-110399-RD

GUN ASSEMBLY (16-0001)			
REF. #	DESCRIPTION	PART #	QTY.
1	Plastic Housing	16-0008	1
2	Screw	27-3230	2
3	Brass Housing	16-0012	1
4	Gun Repair Kit	70-0055	1
5	Brass Plug	39-0024	1
6	Plastic Cover	16-0009	1
7	Pipe Assembly	16-0013	1
8	Trigger Pin	16-0063	1
9	Trigger/Safety Lock-off	16-0010	1
10	Pipe Assembly- Inlet	16-0016	1
	Complete Gun Assembly	16-0001	1

