

# THE **JOB PRO**<sup>®</sup> by **Mi-T-M**<sup>®</sup>

8650 Enterprise Drive, Peosta IA 52068  
563-556-7484 / Fax 563-556-1235  
www.mitm.com

## PARTS LIST FOR ***JP-3004-0MHB/VB*** ***(AFTER SERIAL #10182699)***

**Engine Oil Grade:**

**JP-3004-0MHB:**

**SAE10W-30**

**JP-3004-0MVB:**

**Above 40°F=SAE30**

**Below 40°F=SAE10W-30**

**Engine Oil Capacity:**

**JP-3004-0MHB:**

**37 oz.**

**JP-3004-0MVB:**

**51 oz.**

**Pump Oil Grade:**

**Mi-T-M Pump Oil #AW-4085-0016**

**Pump Oil Capacity:**

**18.5 oz.**

**Nozzle Size:**

**4.0**

This Parts Listing has been compiled for your benefit. You can be assured your Mi-T-M Cold Water Pressure Washer was constructed and designed with quality and performance in mind using over 25 years experience in the pressure washer business. Each component has been rigorously tested to insure the highest level of acceptance.

The contents of this Parts Listing are based on the latest product information available at the time of publication. Mi-T-M reserves the right to make changes in price, color, materials, equipment, specifications or models at any time without notice.

### **WARNING**

THIS IS A PROFESSIONAL HIGH PRESSURE, COLD WATER PRESSURE WASHER. CAUTION SHOULD BE OBSERVED WHEN USING OR REPAIRING THIS UNIT! READ AND FOLLOW THE SAFETY WARNINGS LISTED BELOW BEFORE ATTEMPTING ANY REPAIRS ON THIS PRESSURE WASHER!

### **SAFETY WARNINGS**

1. NEVER alter or modify the equipment. Be sure any accessory items and system components being used will withstand the pressure developed. Use only genuine Mi-T-M parts for repair of your pressure washer. Failure to do so can cause hazardous operating conditions and will VOID warranty.
2. NEVER make adjustments on machinery while the unit is connected to the engine without first removing the ignition cable from the spark plug. Turning over the machinery by hand during adjustment or cleaning might start the engine and machinery with it, causing serious injury to the operator.
3. Know how to stop and bleed pressures quickly. Be thoroughly familiar with controls.
4. Before servicing the unit, turn unit off, relieve the water pressure and allow the unit to cool down. Do not make repairs while the unit is running. Service in a clean, dry, flat area. Block the wheels to prevent the unit from moving. Be especially careful to properly dispose of any flammable materials.
5. After testing the machine, DO NOT leave the pressurized unit unattended. Shut off the unit and release trapped pressure before leaving.

### **Table of Contents**

<b>SPECIFICATIONS</b> .....	<b>3</b>
<b>FRAME ASSEMBLY FOR JP-3004-0MHB/0MVB (AFTER SERIAL #10182699)</b> .....	<b>4</b>
<b>PUMP ASSEMBLY (3-0266)</b> .....	<b>6</b>
<b>UNLOADER ASSEMBLY (8-0533)</b> .....	<b>8</b>
<b>GUN ASSEMBLY (16-0001)</b> .....	<b>10</b>

## SPECIFICATIONS

<b>MODEL NUMBER</b>	<b>JP-3004-0MHB</b>	<b>JP-3004-0MVB</b>
<b>Operating Pressure (PSI/Bar):</b>	3000/206.8	
<b>High Pressure Nozzle:</b>	4.0	
<b>Water Volume (GPM/lpm):</b>	3.5/13.2	
<b>Engine:</b>	Honda	Vanguard
Horsepower	13.0	
Engine Type	4 Stroke, Overhead Valve, Single Cylinder	
Oil Type	SAE 10W-30	Above 40°F = SAE30/ Below 40°F = SAE10W-30
Oil Capacity (oz./liters)	37/1.1	51/1.5
Low Oil Protection	Oil Alert™	Oil Guard™
Fuel Type	Unleaded Gasoline 86 Octane Minimum	
Fuel Capacity (gallon/ liters)	1.7/6.5	2.0/7.9
Starting	Recoil	
Maximum No Load RPM	3600 (+/- 100) RPM	
<b>Pump:</b>	Direct Driven, Oil Bath, Triplex Piston	
Oil Type	Mi-T-M Pump Oil #AW-4085-0016	
Oil Capacity (oz./liters)	18.5/55	
Plungers	Ceramic	
Manifold	Forged Brass	
Valves	Stainless Steel	
Unloader	Adjustable	
Thermal Relief Valve	Relieves heated water during unloader bypass stage	
<b>Unit Net Weight (lbs/Kg)</b>	136/62	140/64
<b>Unit Shipping Weight (lbs/Kg)</b>	186/85	190/87
<b>Unit Net Dimension (in/cm)</b>	35Lx22.5Wx26H/89Lx57Wx66H	
<b>Unit Shipping Dimension (in/cm)</b>	39.5Hx25Wx31.5H/100.5Lx63.5Wx80H	

# FRAME ASSEMBLY FOR JP-3004-0MHB/0MVB (AFTER SERIAL #10182699)

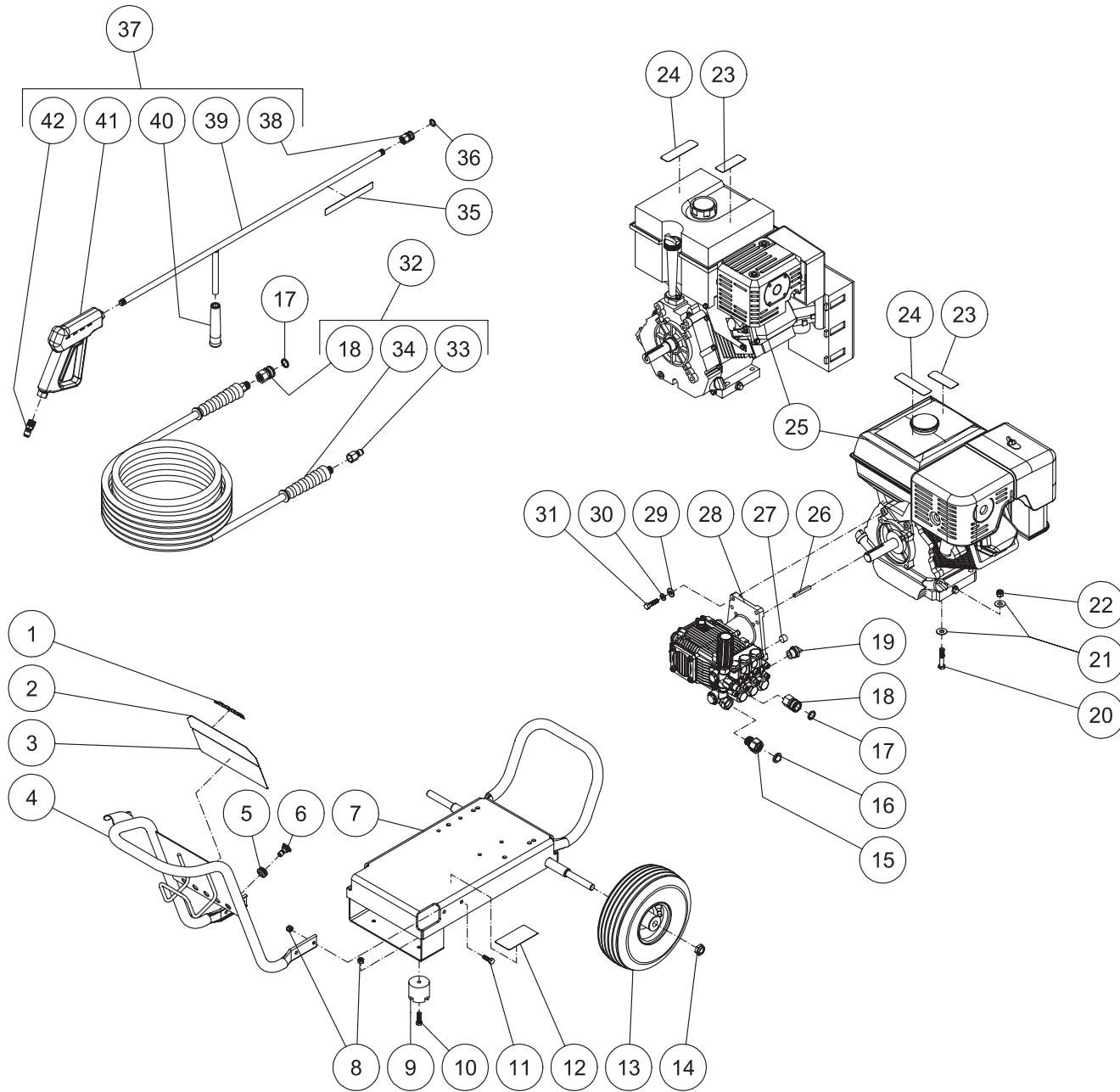

JP-3004-0MHB-041206-JJT

FRAME ASSEMBLY FOR JP-3004-0MHB/0MVB (AFTER SERIAL #10182699)							
REF. #	DESCRIPTION	PART #	QTY.	REF. #	DESCRIPTION	PART #	QTY.
1	Decal- 3000 Die Cut	34-0775	1	22	Locknut	30-0159	4
2	Decal- Job Pro Placard	34-0778	1	23	Decal- Caution: Risk of Fire (See 34-9014)	N/A Sep.	1
3	Decal- Warning/Caution/Operating (See 34-9014)	N/A Sep.	1	24	Decal- Warning: Risk of Burns (See 34-9014)	N/A Sep.	1
4	Front Handle Assembly	7-0194A01	1	25	Engine- 11.0 H.P. Honda (JP-3004-0MHB)	1-0039	1
5	Grommet	33-0001	5	-	Engine- 11.0 H.P. Vanguard (JP-3004-0MVB)	1-0089	1
6	Nozzle- 0004	18-0028	1	26	Key	43-0078	1
-	Nozzle- 1504	18-0029	1	27	Plug	23-0244	1
-	Nozzle- 2504	18-0030	1	28	Pump	3-0266	1
7	Frame	5-0254A01	1	29	Washer	28-0022	4
8	Locknut	30-0157	2	30	Lockwasher	29-0008	4
9	Isolator	14-0008	2	31	Bolt	27-0118	4
10	Bolt	27-0068	2	32	Pressure Hose Assembly (Inc. 18, 33-34)	851-0007	1
11	Bolt	27-0067	4	33	Quick Connect Plug	17-0006	1
12	Decal- Data Plate	N/A	1	34	Pressure Hose	15-0003	1
13	Wheel	14-0017	2	35	Decal- Warning: Risk of Injection (See 34-9014)	N/A Sep.	1
14	Jam Nut	30-0117	2	36	O-ring (Replacement Only)	25-0122	-
15	Garden Hose Swivel	23-0095	1	37	Gun/Wand Assembly (Inc. 38-42)	851-0095	1
16	Filter	19-0001	1	38	Quick Connect Plug	17-0001	1
17	O-ring (Replacement Only)	25-0123	-	39	Wand w/ Handle	16-0418	1
18	Quick Connect Socket	17-0004	2	40	Grip Handle	7-0002	1
19	Thermal Relief Valve	22-0005	1	41	Gun	16-0001	1
20	Bolt	27-0121	4	42	Quick Connect Plug	17-0005	1
21	Washer	28-0023	8		Safety Decal Kit (Inc. 3, 23-24, 35)	34-9014	

\*Must Order in One Foot Lengths

# PUMP ASSEMBLY (3-0266)

TORQUE SPECS.	
POSITION	FT-LBS
1	18
6	7.4
10	4
25	7.4
33	18
34	40
40	18

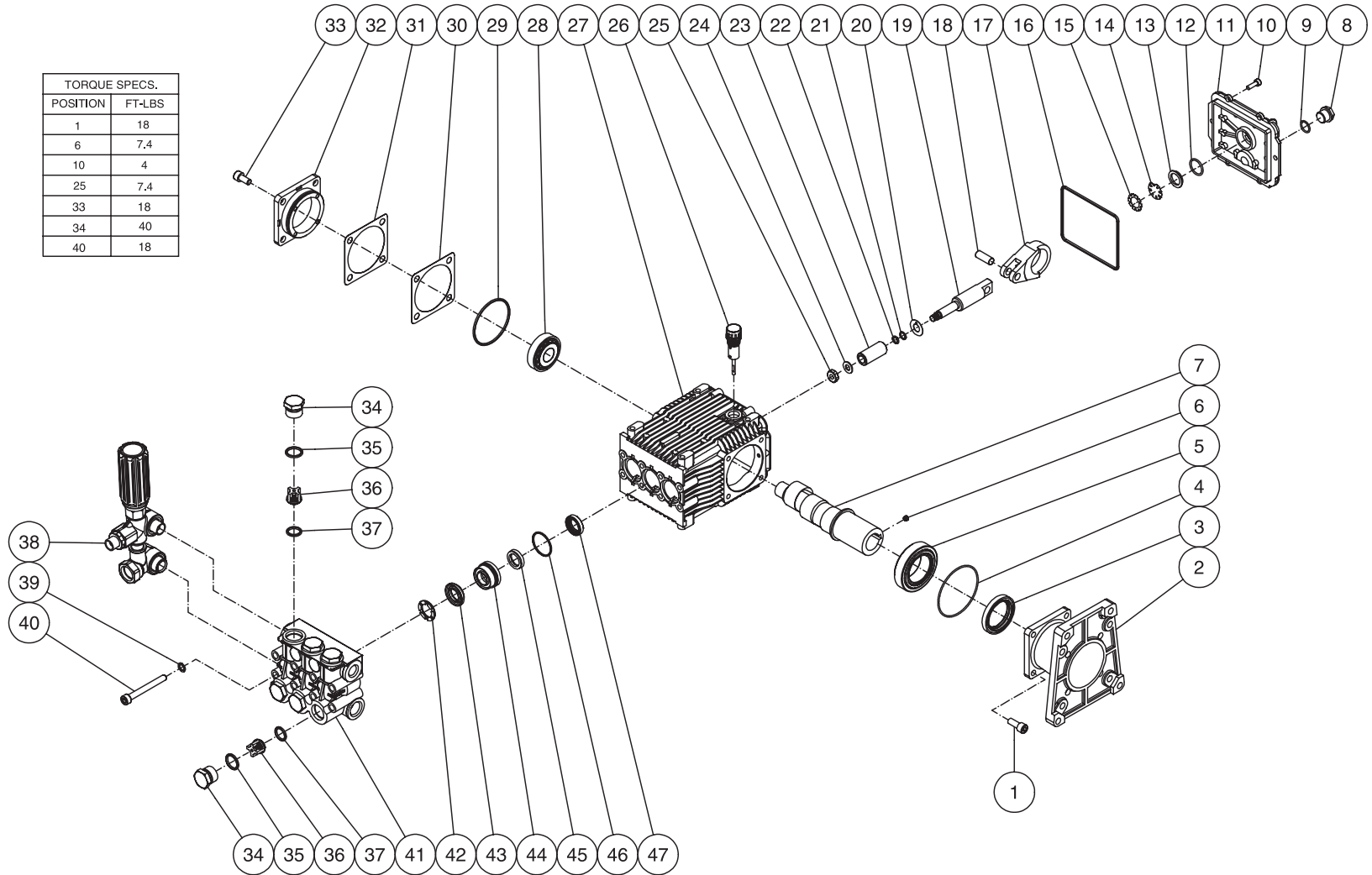

3-0266-032405-JJF

## PUMP ASSEMBLY (3-0266)

REF. #	DESCRIPTION	PART #	QTY.	REF. #	DESCRIPTION	PART #	QTY.	REF. #	DESCRIPTION	PART #	QTY.
1	Screw	27-8432	4	19	Plunger Rod	46-0699	3	37	O-ring	25-0386	6
2	Pump Flange	46-0714	1	20	Washer	46-0700	3	38	Unloader Assembly	8-0533	1
3	Oil Seal	26-0194	1	21	Back-up Ring	25-0404	3	39	Lockwasher	29-0154	8
4	O-ring	25-0397	1	22	O-ring	25-0382	3	40	Screw	27-8440	8
5	Bearing	48-0062	1	23	Piston	46-0701	3	41	Manifold	46-1186	1
6	Screw	27-8886	1	24	Washer / Gasket	26-0191	3	42	Support Ring (See 70-0178)	N/A Sep.	3
7	Crankshaft	46-0959	1	25	Nut	30-6020	3	43	V-Packing (See 70-0177)	N/A Sep.	3
8	Plug	39-0086	1	26	Oil Dipstick	39-0090	1	44	Packing Retainer	46-0708	3
9	O-ring	25-0325	1	27	Pump Crankcase	46-0811	1	45	Low Pressure Seal (See 70-0177)	N/A Sep.	3
10	Screw	27-8885	6	28	Bearing	48-0072	1	46	O-ring	25-0384	3
11	Pump	46-0719	1	29	O-ring	25-0380	1	47	Oil Seal	46-0931	3
12	O-ring	25-0370	1	30	Shim- 0.2mm (Qty. Varies 1-3)	46-0705	1		Oil Seals Kit (Inc. 3, 4, 16, 29, 47)	70-0337	
13	Oil Sight Glass	46-0670	1	31	Shim- 0.1mm (Qty. Varies 1-3)	46-0704	1		Piston Kit (Inc. 3 each 20-25)	70-0352	
14	Oil Reflector	46-0824	1	32	Bearing Cap	46-0703	1		High Pressure Seals Kit (Inc. 3 each 43, 45, 46)	70-0177	
15	Spring Retainer	46-0671	1	33	Screw	27-8884	4		Support Ring Kit (Inc. 3 each 42)	70-0178	
16	O-ring	25-0398	1	34	Valve Cap	39-0095	6		Valve Kit (Inc. 6 each 36, 37)	70-0179	
17	Connecting Rod	46-0922	3	35	O-ring	25-0160	6				
18	Piston Pin	46-0698	3	36	Complete Valve (See 70-0179)	N/A Sep.	6				

# UNLOADER ASSEMBLY (8-0533)

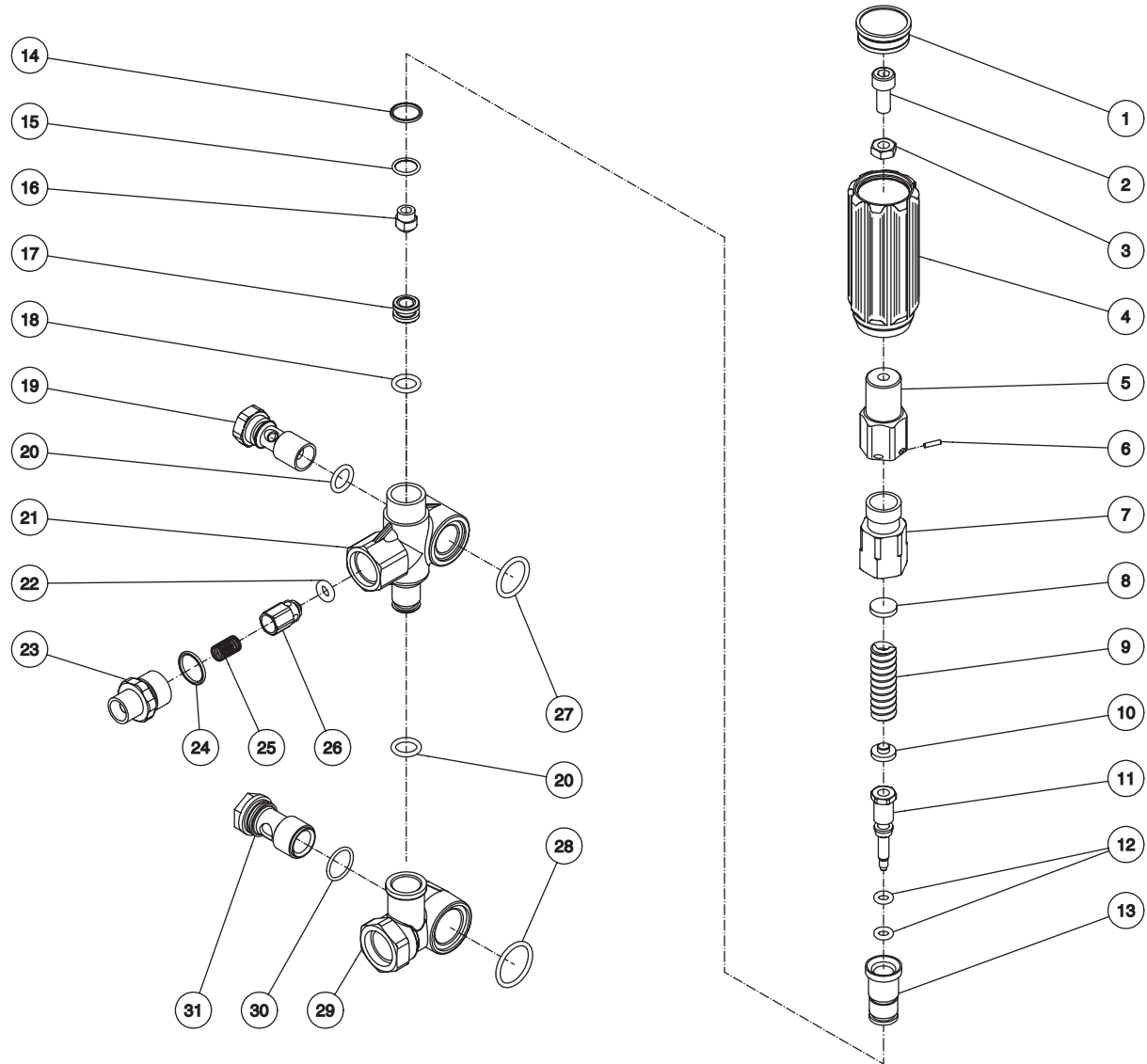

8-0533-102104-JJF



## UNLOADER ASSEMBLY (8-0533)

REF. #	DESCRIPTION	PART #	QTY.	REF. #	DESCRIPTION	PART #	QTY.
1	Unloader Cap	7-0142	1	17	Seat	8-0529	1
2	Screw	27-8433	1	18	O-ring	25-0527	1
3	Nut	30-3025	1	19	Bolt	8-0531	1
4	Unloader Knob	7-0141	1	20	O-ring	25-0388	2
5	Unloader	8-0476	1	21	Unloader Body	8-0530	1
6	Unloader Pin	8-0478	1	22	O-ring	25-0437	1
7	Spring Guide	8-0523	1	23	Adapter Nipple	24-0159	1
8	Upper Plate	8-0524	1	24	O-ring	25-0372	1
9	Unloader Spring	49-0132	1	25	Unloader Check Valve Spring	49-0123	1
10	Lower Plate	8-0525	1	26	Unloader Check Valve	8-0454	1
11	Piston	8-0526	1	27	O-ring	25-0528	1
12	O-ring	25-0526	2	28	O-ring	25-0519	1
13	Piston Guide	8-0527	1	29	Bypass Housing	8-0532	1
14	O-ring	25-0510	1	30	O-ring	25-0389	1
15	O-ring	25-0407	1	31	Bolt	8-0517	1
16	Bypass Jet	8-0528	1		Unloader Repair Kit (Inc. 12, 14-15, 18, 20, 22, 24, 27, 28, 30)	70-0341	

# GUN ASSEMBLY (16-0001)

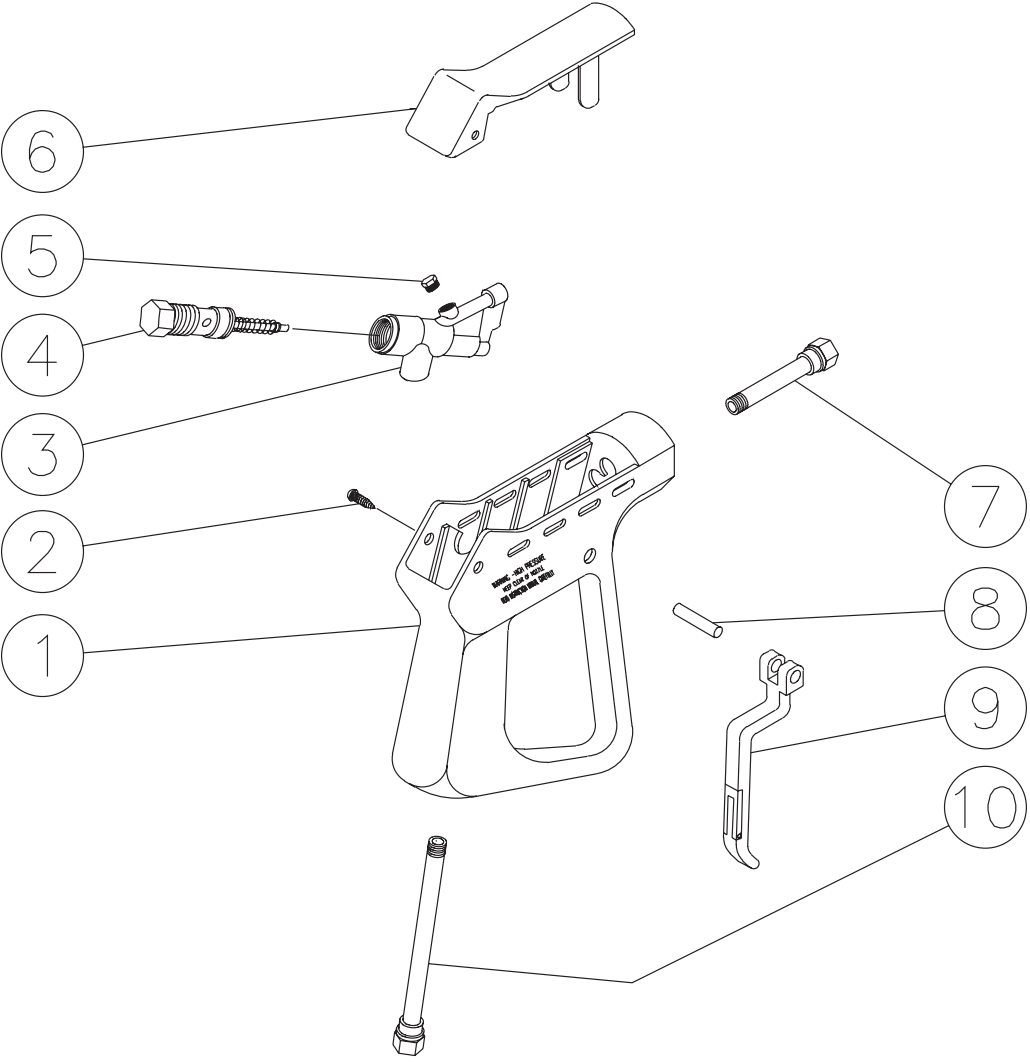

<b>GUN ASSEMBLY (16-0001)</b>			
<b>REF. #</b>	<b>DESCRIPTION</b>	<b>PART #</b>	<b>QTY.</b>
1	Plastic Housing	16-0008	1
2	Screw	27-3230	2
3	Brass Housing	16-0012	1
4	Gun Repair Kit	70-0055	1
5	Brass Plug	39-0024	1
6	Plastic Cover	16-0009	1
7	Pipe Assembly	16-0013	1
8	Trigger Pin	16-0063	1
9	Trigger/Safety Lock-off	16-0010	1
10	Pipe Assembly- Inlet	16-0016	1
	Complete Gun Assembly	16-0001	1

