

# Mi-T-M<sup>®</sup> CORPORATION

8650 Enterprise Drive, Peosta IA 52068  
563-556-7484 / Fax 563-556-1235  
[www.mitm.com](http://www.mitm.com)

## PARTS LIST FOR ***CW-3005-0ME1/0ME3*** ***(after serial #10375000)***

Motor Horsepower:  
Pump Oil Grade:  
Pump Oil Capacity:  
Nozzle Size:

10 H.P.  
Mi-T-M Pump Oil #AW-4085-0016  
41 oz.  
5.5

This Parts Listing has been compiled for your benefit. You can be assured your Mi-T-M Cold Water Pressure Washer was constructed and designed with quality and performance in mind using over 25 years experience in the pressure washer business. Each component has been rigorously tested to insure the highest level of acceptance.

The contents of this Parts Listing are based on the latest product information available at the time of publication. Mi-T-M reserves the right to make changes in price, color, materials, equipment, specifications or models at any time without notice.

**WARNING**

THIS IS A PROFESSIONAL HIGH PRESSURE, COLD WATER PRESSURE WASHER. CAUTION SHOULD BE OBSERVED WHEN USING OR REPAIRING THIS UNIT! READ AND FOLLOW THE SAFETY WARNINGS LISTED BELOW BEFORE ATTEMPTING ANY REPAIRS ON THIS PRESSURE WASHER!

**SAFETY WARNINGS**

1. NEVER alter or modify the equipment. Be sure any accessory items and system components being used will withstand the pressure developed. Use only genuine Mi-T-M parts for repair of your pressure washer. Failure to do so can cause hazardous operating conditions and will VOID warranty.
2. NEVER make adjustments on machinery while the unit is connected to the engine without first removing the ignition cable from the spark plug. Turning over the machinery by hand during adjustment or cleaning might start the engine and machinery with it, causing serious injury to the operator.
3. Know how to stop and bleed pressures quickly. Be thoroughly familiar with controls.
4. Before servicing the unit, turn unit off, relieve the water pressure and allow the unit to cool down. Do not make repairs while the unit is running. Service in a clean, dry, flat area. Block the wheels to prevent the unit from moving. Be especially careful to properly dispose of any flammable materials.
5. After testing the machine, DO NOT leave the pressurized unit unattended. Shut off the unit and release trapped pressure before leaving.

**Table of Contents**

**SPECIFICATIONS.....3**

**FRAME ASSEMBLY FOR CW-3005-0ME1 .....4**

**FRAME ASSEMBLY FOR CW-3005-0ME3 .....6**

**PUMP ASSEMBLY (3-0202) (AFTER SERIAL #10375000).....8**

**UNLOADER ASSEMBLY (8-0032) .....10**

**GUN ASSEMBLY (16-0001) .....12**

**ELECTRIC BOX FOR CW-3005-0ME1 (230 VOLT).....14**

**WIRING SCHEMATIC FOR CW-3005-0ME1 (230 VOLT).....16**

**WIRING DIAGRAM FOR CW-3005-0ME1 (230 VOLT).....17**

**ELECTRIC BOX FOR CW-3005-0ME3 (230 VOLT).....18**

**WIRING SCHEMATIC FOR CW-3005-0ME3 (230 VOLT).....20**

**WIRING DIAGRAM FOR CW-3005-0ME3 (230 VOLT).....21**

**ELECTRIC BOX FOR CW-3005-0ME3 (CX-0062 OPTION) (480 VOLT) .....22**

**WIRING SCHEMATIC FOR CW-3005-0ME3 (CX-0062 OPTION) (480 VOLT).....24**

**WIRING DIAGRAM FOR CW-3005-0ME3 (CX-0062 OPTION) (480 VOLT) .....25**

## SPECIFICATIONS

MODEL NUMBER	CW-3005-0ME1	CW-3005-0ME3
<b>Operating Pressure (PSI/Bar):</b>	3000/206.8	
<b>High Pressure Nozzle:</b>	5.5	
<b>Water Volume (GPM/lpm):</b>	4.8/18.2	
<b>Motor:</b>	TEFC	
Horsepower	10.0	
RPM	1750	
Amperage	37.5	25
Service Factor	1.00	1.15
<b>Pump:</b>	Belt or Direct Driven, Oil Bath, Triplex Piston	
Oil Type	Mi-T-M Pump Oil #AW-4085-0016	
Oil Capacity (oz./liters)	41/1.2	
Plungers	Ceramic	
Manifold	Forged Brass	
Valves	Stainless Steel	
<b>Unloader:</b>	Pre-set at the factory	
<b>Heat Dump Valve:</b>	Relieves heated water during unloader bypass stage	
<b>Unit Net Weight (lbs/Kg)</b>	329/149	379/172
<b>Unit Shipping Weight (lbs/Kg)</b>	470/213	520/236
<b>Unit Net Dimension (in/cm)</b>	45.5Lx32.5Wx30H/115.5Lx82.5Wx76.5H	
<b>Unit Shipping Dimension (in/cm)</b>	48.5Lx30.5Wx35.5H/123Lx77.5Wx90H	

# FRAME ASSEMBLY FOR CW-3005-0ME1

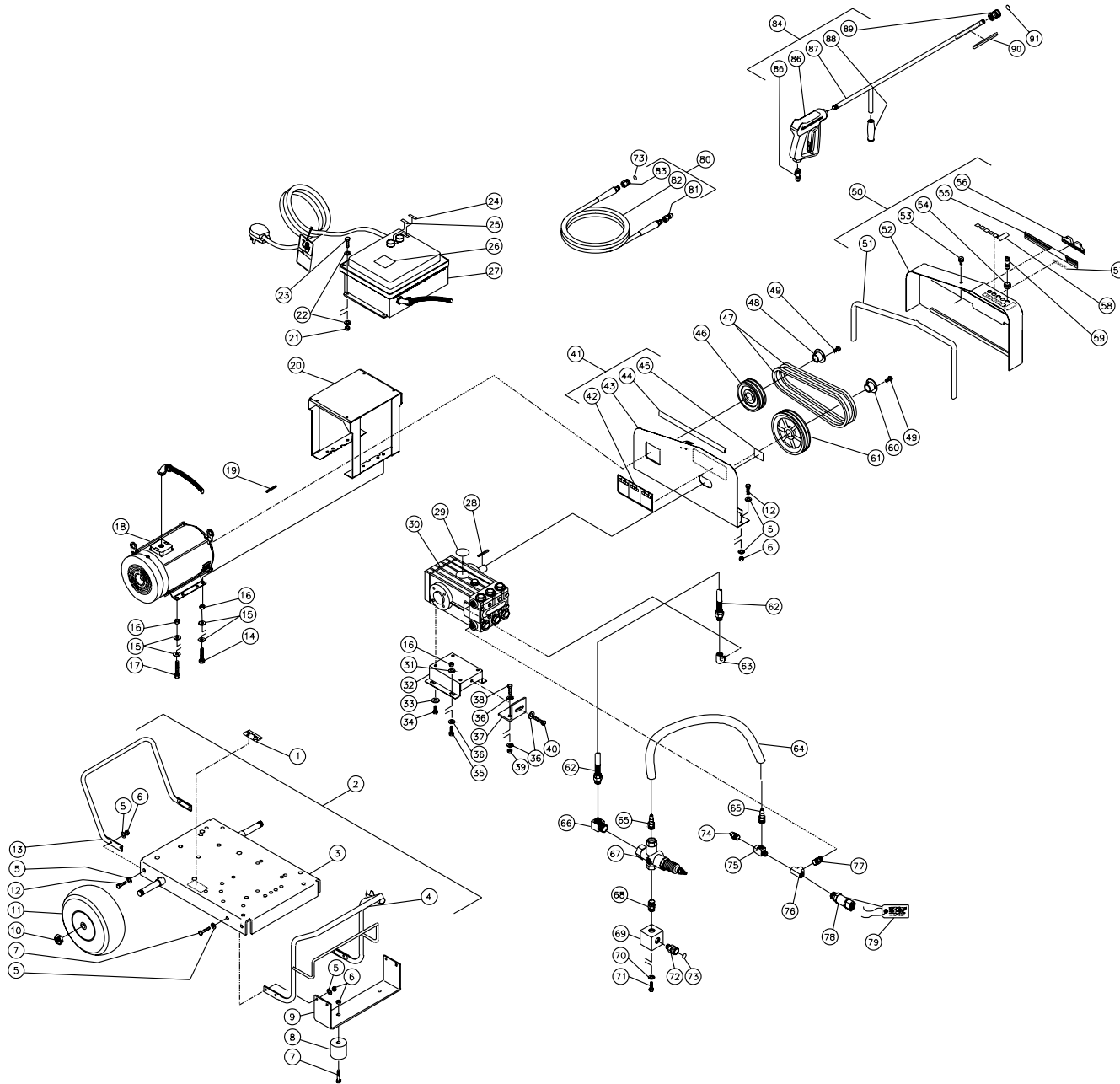

CW-3005-0ME1-070901-RD

FRAME ASSEMBLY FOR CW-3005-0ME1											
REF. #	DESCRIPTION	PART #	QTY.	REF. #	DESCRIPTION	PART #	QTY.	REF. #	DESCRIPTION	PART #	QTY.
1	Decal- Data Plate	N/A	1	33	Washer w/Pump	29-0055	4	62	Hose	15-0024	1
2	Base Plate Assembly (Inc. 3-13)	851-0333	1	34	Bolt w/Pump	27-8471	4	63	Hose Fitting	24-0105	1
3	Base Plate	5-0137A01	1	35	Bolt	27-0166	4	64	By-Pass Hose *(Two Feet Required)	15-0033	1
4	Handle	7-0102A01	1	36	Washer	28-0023	9	65	Fitting	23-0007	2
5	Washer	28-0003	30	37	Brace Tightener	13-0003A01	1	66	Fitting	24-0006	1
6	Locknut	30-0157	17	38	Bolt	27-0118	2	67	Unloader	8-0032	1
7	Bolt	27-0068	6	39	Locknut	30-0159	2	68	Fitting	24-0031	1
8	Isolator	14-0008	2	40	Bolt	27-0576	1	69	Manifold Block	51-0012	1
9	Underbracket	13-0015A01	1	41	Beltguard Assembly- Back (Inc. 42-45)	851-0335	1	70	Washer	29-0008	2
10	Jamnut	30-0117	2	42	Decal- Warning/Caution/Operation	34-0925	1	71	Bolt	27-0116	2
11	Wheel	14-0006	2	43	Beltguard- Back (See 851-0335)	N/A Sep.	1	72	Quick Connect Socket	17-0029	1
12	Bolt	27-0067	11	44	Edging *(Two Feet Required)	33-0020	1	73	O-ring (Replacement Only)	25-0123	-
13	Handle	7-0105A01	1	45	Decal- Warning: Beltguard Cover	34-0575	1	74	Heat-Dump Valve	22-0005	1
14	Bolt	27-0170	2	46	Sheave	10-0104	1	75	Street Tee Fitting	23-0043	1
15	Washer	28-0024	8	47	Belt	11-0009	2	76	Fitting	23-0124	1
16	Locknut	30-0161	8	48	Bushing	9-0008	1	77	Fitting	23-0012	1
17	Bolt	27-0168	2	49	Bolt w/Bushing	27-0015	6	78	Strainer	19-0206	1
18	Motor- 15 H.P.	2-0094	1	50	Beltguard Cover Assembly (Inc. 51-56)	850-0242	1	79	Tag- Water Supply Inlet	34-0097	1
19	Key	43-0078	1	51	Edging *(Four Feet Required)	33-0020	1	80	Pressure Hose Assembly (Inc. 81-83)	851-0007	1
20	Bracket	20-0578A01	1	52	Beltguard Cover (See 850-0242)	N/A Sep.	1	81	Quick Connect Plug	17-0006	1
21	Locknut	30-0155	4	53	Fastner	33-0197	1	82	Pressure Hose	15-0003	1
22	Washer	28-0002	8	54	Grommet	33-0001	5	83	Quick Connect Socket	17-0004	1
23	Bolt	27-0016	4	55	Decal- Mi-T-M Stripe	34-0501	1	84	Gun/Wand Assembly (Inc. 85-89)	851-0095	1
24	Decal- Stop	34-0249	1	56	Mi-T-M Logo	62-0087	1	85	Quick Connect Plug	17-0005	1
25	Decal- Run	34-0250	1	57	Decal- Die Cut 3005	34-0039	1	86	Gun	16-0001	1
26	Decal- Do not Spray	34-0391	1	58	Decal- Die Cut Nozzles	34-0500	1	87	Wand- w/ 36" Handle	16-0120A01	1
27	Electrical Box Assembly (See Exploded Drawing)	N/A Sep.	1	59	Spray Nozzle- 0005.5	18-0035	1	88	Grip Handle	7-0002	1
28	Key w/Pump	43-0028	1	-	Spray Nozzle- 1505.5	18-0041	1	89	Quick Connect Socket	17-0001	1
29	Decal- 3-0202	34-1036	1	-	Spray Nozzle- 2505.5	18-0062	1	90	Decal- Risk of Injection	34-0572	1
30	Pump	3-0202	1	-	Spray Nozzle- 4005.5	18-0132	1	91	O-ring (Replacement Only)	25-0122	-
31	Washer	28-0030	4	60	Bushing	9-0017	1	*Must Order in One Foot Lengths			
32	Pump Bracket	5-0101A01	1	61	Sheave	10-0007	1				

# FRAME ASSEMBLY FOR CW-3005-0ME3

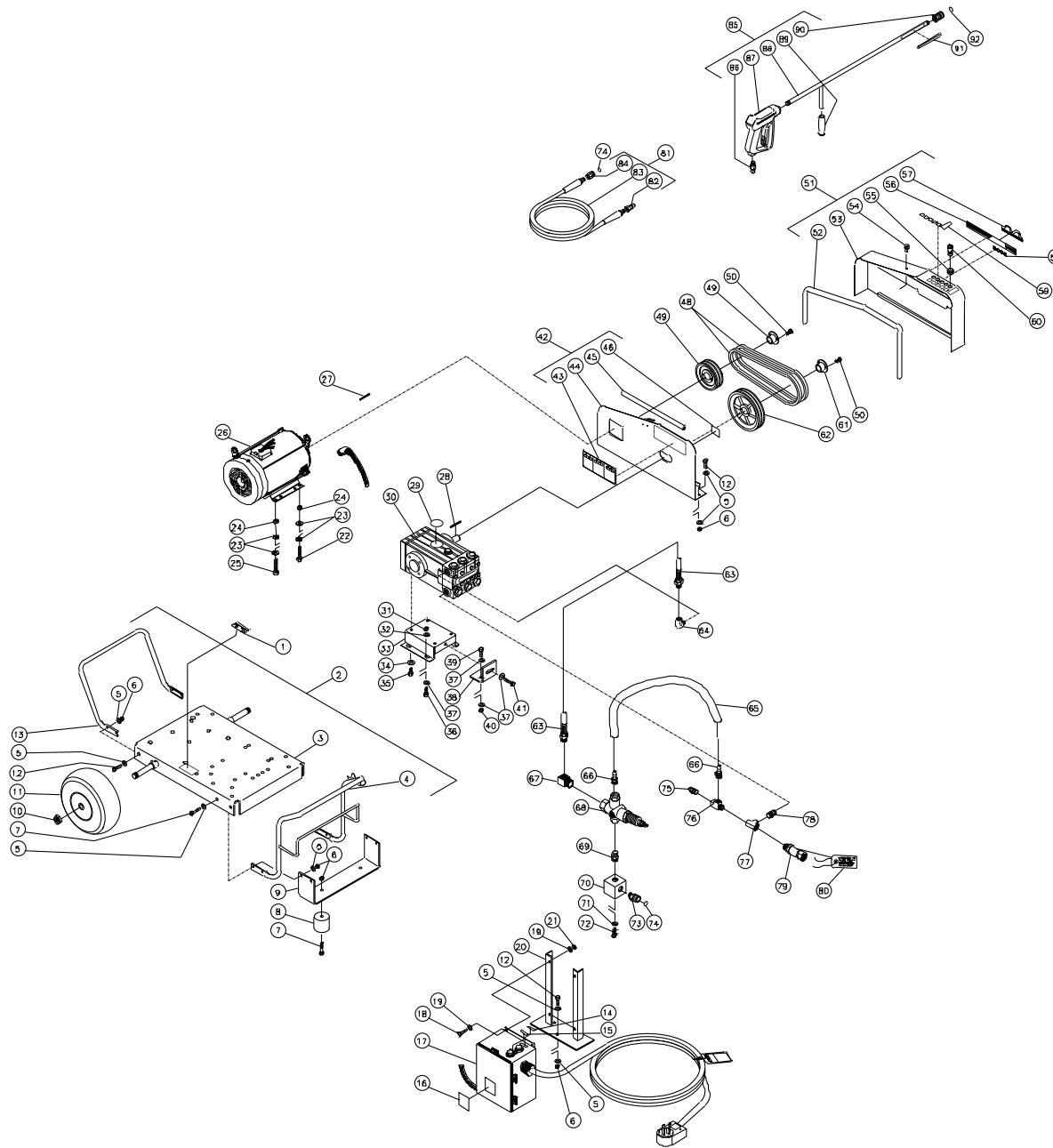

CW-3005-0ME3-041003-RD

FRAME ASSEMBLY FOR CW-3005-0ME3											
REF. #	DESCRIPTION	PART #	QTY.	REF. #	DESCRIPTION	PART #	QTY.	REF. #	DESCRIPTION	PART #	QTY.
1	Decal- Data Plate	N/A	1	32	Washer	28-0030	4	61	Bushing	9-0017	1
2	Base Plate Assembly (Inc. 3-13)	851-0333	1	33	Pump Bracket	5-0101A01	1	62	Sheave	10-0104	1
3	Base Plate	5-0137A01	1	34	Washer w/Pump	29-0055	4	63	Hose	15-0024	1
4	Handle	7-0102A01	1	35	Bolt w/Pump	27-8471	4	64	Hose Fitting	24-0105	1
5	Washer	28-0003	30	36	Bolt	27-0166	4	65	By-Pass Hose *(Two Feet Required)	15-0033	1
6	Locknut	30-0157	17	37	Washer	28-0023	9	66	Fitting	23-0007	2
7	Bolt	27-0068	6	38	Brace Tightener	13-0003A01	1	67	Fitting	24-0006	1
8	Isolator	14-0008	2	39	Bolt	27-0118	2	68	Unloader	8-0032	1
9	Underbracket	13-0015A01	1	40	Locknut	30-0159	2	69	Fitting	24-0031	1
10	Jamnut	30-0117	2	41	Bolt	27-0576	1	70	Manifold Block	51-0012	1
11	Wheel	14-0006	2	42	Beltguard Assembly- Back (Inc. 43-46)	851-0335	1	71	Washer	29-0008	2
12	Bolt	27-0067	11	43	Decal- Warning/Caution/Operation	34-0925	1	72	Bolt	27-0116	2
13	Handle	7-0105A01	1	44	Beltguard- Back (See 851-0335)	N/A Sep.	1	73	Quick Connect Socket	17-0029	1
14	Decal- Stop	34-0249	1	45	Edging *(Two Feet Required)	33-0020	1	74	O-ring (Replacement Only)	25-0123	-
15	Decal- Run	34-0250	1	46	Decal- Warning: Beltguard Cover	34-0575	1	75	Heat-Dump Valve	22-0005	1
16	Decal- Do Not Spray	34-0391	1	47	Sheave	10-0041	1	76	Street Tee Fitting	23-0043	1
17	Electrical Box Assembly (See Exploded Drawing)	N/A Sep.	1	48	Belt	11-0017	2	77	Fitting	23-0124	1
-	Electrical Box Assembly (CX-0062) (See Exploded Drawing)	N/A Sep.	1	49	Bushing	9-0008	1	78	Fitting	23-0012	1
18	Bolt	27-0015	4	50	Bolt w/Bushing	27-0015	6	79	Strainer	19-0206	1
19	Washer	28-0002	8	51	Beltguard Cover Assembly (Inc. 52-57)	850-0242	1	80	Tag- Water Supply Inlet	34-0097	1
20	Bracket	13-0127A01	1	52	Edging *(Four Feet Required)	33-0020	1	81	Pressure Hose Assembly (Inc. 82-84)	851-0007	1
21	Locknut	30-0155	4	53	Beltguard Cover (See 850-0242)	N/A Sep.	1	82	Quick Connect Plug	17-0006	1
22	Bolt	27-0220	2	54	Fastner	33-0197	1	83	Pressure Hose	15-0003	1
23	Washer	28-0006	8	55	Grommet	33-0001	5	84	Quick Connect Socket	17-0004	1
24	Locknut	30-0163	4	56	Decal- Mi-T-M Stripe	34-0501	1	85	Gun/Wand Assembly (Inc. 86-90)	851-0095	1
25	Bolt	27-0219	2	57	Mi-T-M Logo	62-0087	1	86	Quick Connect Plug	17-0005	1
26	Motor- 15 H.P.	2-0095	1	58	Decal- Die Cut 3005	34-0039	1	87	Gun	16-0001	1
27	Key	43-0078	1	59	Decal- Die Cut Nozzles	34-0500	1	88	Wand- w/ 36" Handle	16-0120A01	1
28	Key w/Pump	43-0028	1	60	Spray Nozzle- 0005.5	18-0035	1	89	Grip Handle	7-0002	1
29	Decal- 3-0202	34-1036	1	-	Spray Nozzle- 1505.5	18-0041	1	90	Quick Connect Socket	17-0001	1
30	Pump	3-0202	1	-	Spray Nozzle- 2505.5	18-0062	1	91	Decal- Risk of Injection	34-0572	1
31	Locknut	30-0161	4	-	Spray Nozzle- 4005.5	18-0132	1	92	O-ring (Replacement Only)	25-0122	-

\*Must Order in One Foot Lengths

# PUMP ASSEMBLY (3-0202) (AFTER SERIAL #10375000)

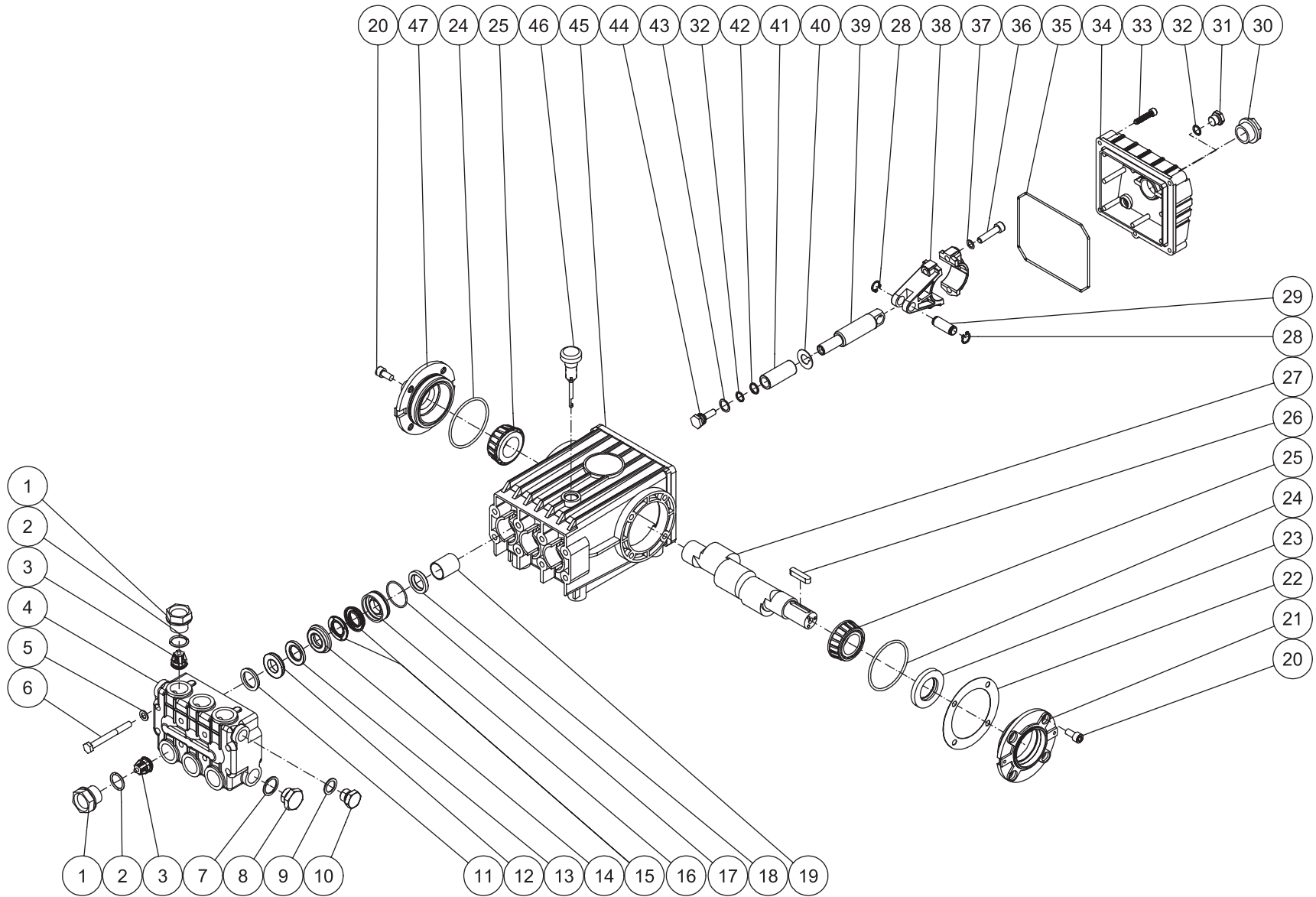

3-0202\_0-0203-010408-JJT



## PUMP ASSEMBLY

REF. #	DESCRIPTION	PART #	QTY.	REF. #	DESCRIPTION	PART #	QTY.	REF. #	DESCRIPTION	PART #	QTY.
1	Valve Plug	46-0889	6	18	Oil Seal	26-0047	3	35	O-ring Cover	25-0339	1
2	O-ring	25-0012	6	19	Bushing	9-0029	3	36	Bolt	27-8435	6
3	Valve Assembly (See 70-0009)	N/A Sep.	6	20	Bolt	27-8431	8	37	Lockwasher	29-0154	6
4	Manifold	46-0890	1	21	Crankcase Open Cover	46-0296	1	38	Connecting Rod	46-0051	3
5	Flatwasher	28-1039	8	22	Shim	46-0113	1	39	Piston Rod	46-0056	3
6	Bolt	27-8185	8	23	Oil Seal	26-0049	1	40	Washer	46-0146	3
7	Washer	28-1038	2	24	O-ring	25-0013	2	41	Plunger	46-0052	3
8	Plug	39-0019	2	25	Bearing	48-0012	2	42	Back-up Ring	46-0109	3
9	Washer	28-1002	2	26	Key	43-0048	1	43	Washer	28-0400	3
10	Plug	39-0018	2	27	Crankshaft	N/A	1	44	Bolt	46-0069	3
11	O-ring (See 70-0030)	N/A Sep.	3	28	Retaining Ring	46-0103	6	45	Crankcase	46-0047	1
12	V-Packing	26-0098	3	29	Connecting Rod Pin	43-0032	3	46	Oil Dip Stick	46-0144	1
13	Ring	25-0207	3	30	Oil Level Indicator	46-0114	1	47	Crankcase Cover	46-0336	1
14	High Pressure Intermediate Seal Retainer	46-0659	3	31	Plug	39-0017	1		Valve Kit (6 each 3)	70-0009	
15	Low Pressure Seal	N/A Sep.	3	32	O-ring	25-0014	4		Head Ring Kit (3 each 11)	70-0030	
16	Low Pressure Seal Retainer	46-0057	3	33	Bolt	27-8404	5		V-Packing Kit (3 each 12, 13, 15)	70-0147	
17	O-ring	25-0015	3	34	Crankcase Cover	46-0295	1		Intermediate Retainer Kit (3 each 13, 14)	70-0148	
									V-Packing Assembly (3 each 11-17)	852-0122	

UNLOADER ASSEMBLY (8-0032)

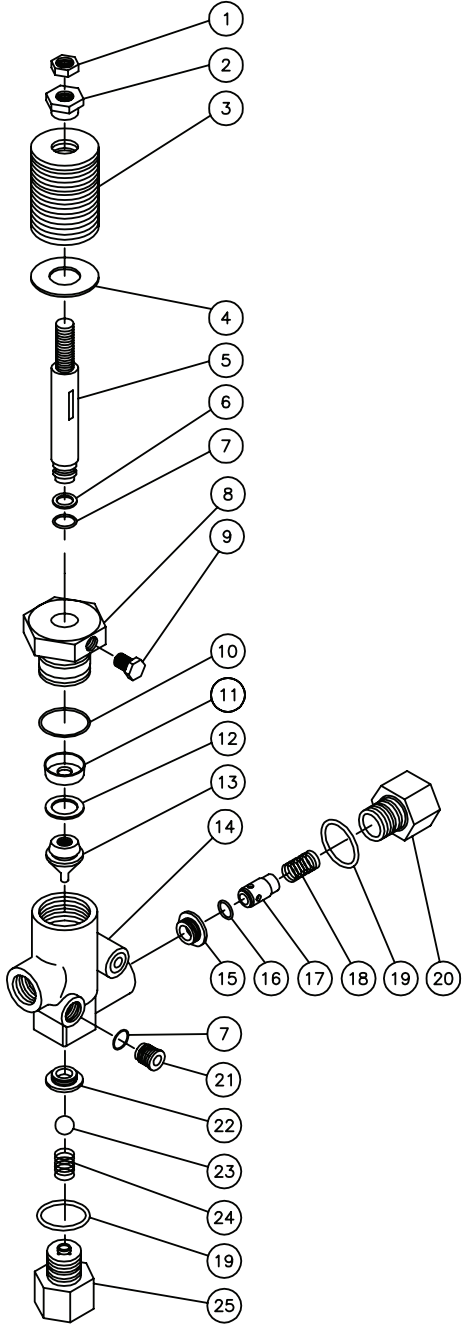

UNLOADER ASSEMBLY (8-0032)			
REF.#	DESCRIPTION	PART #	QTY.
1	Locknut	30-3058	1
2	Adjusting Nut	8-0089	1
3	Spring Washers - Orange	8-0009	15
4	Washer	28-0250	1
5	Valve Stem	8-0037	1
6	Backup Ring	8-0038	1
7	O-ring	25-0009	5
8	Valve Cap	8-0036	1
9	Set Screw	8-0084	1
10	O-ring	25-0008	1
11	Cup	8-0034	1
12	Back-up Ring	8-0040	1
13	Piston	8-0039	1
14	Valve Body	8-0164	1
15	Outlet Seat	8-0006	1
16	O-ring	25-0011	1
17	Outlet Valve	8-0004	1
18	Spring	49-0016	1
19	O-ring	25-0010	2
20	Outlet Retainer	8-0003	1
21	Brass Plug	8-0011	4
22	Valve Seat	8-0005	1
23	Ball	8-0041	1
24	Spring	49-0015	1
25	Inlet Retainer	8-0165	1
	Unloader Repair Kit (Inc. 6, 7, 10-12, 16 and 19)	70-0044	

# GUN ASSEMBLY (16-0001)

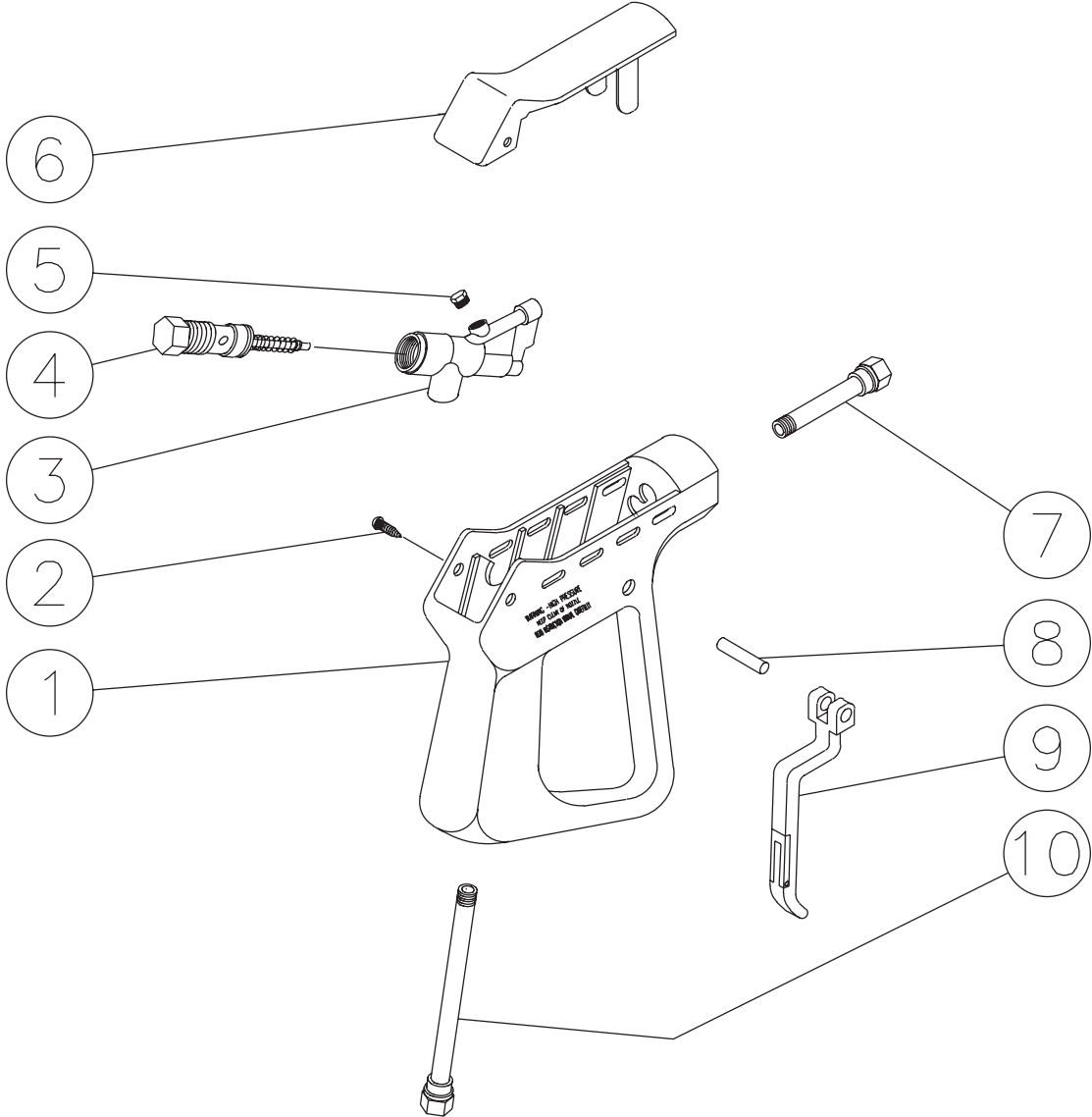

<b>GUN ASSEMBLY (16-0001)</b>			
<b>REF. #</b>	<b>DESCRIPTION</b>	<b>PART #</b>	<b>QTY.</b>
1	Plastic Housing	16-0008	1
2	Screw	27-3230	2
3	Brass Housing	16-0012	1
4	Gun Repair Kit	70-0055	1
5	Brass Plug	39-0024	1
6	Plastic Cover	16-0009	1
7	Pipe Assembly	16-0013	1
8	Trigger Pin	16-0063	1
9	Trigger/Safety Lock-off	16-0010	1
10	Pipe Assembly- Inlet	16-0016	1
	Complete Gun Assembly	16-0001	1

# ELECTRIC BOX FOR CW-3005-0ME1 (230 VOLT)

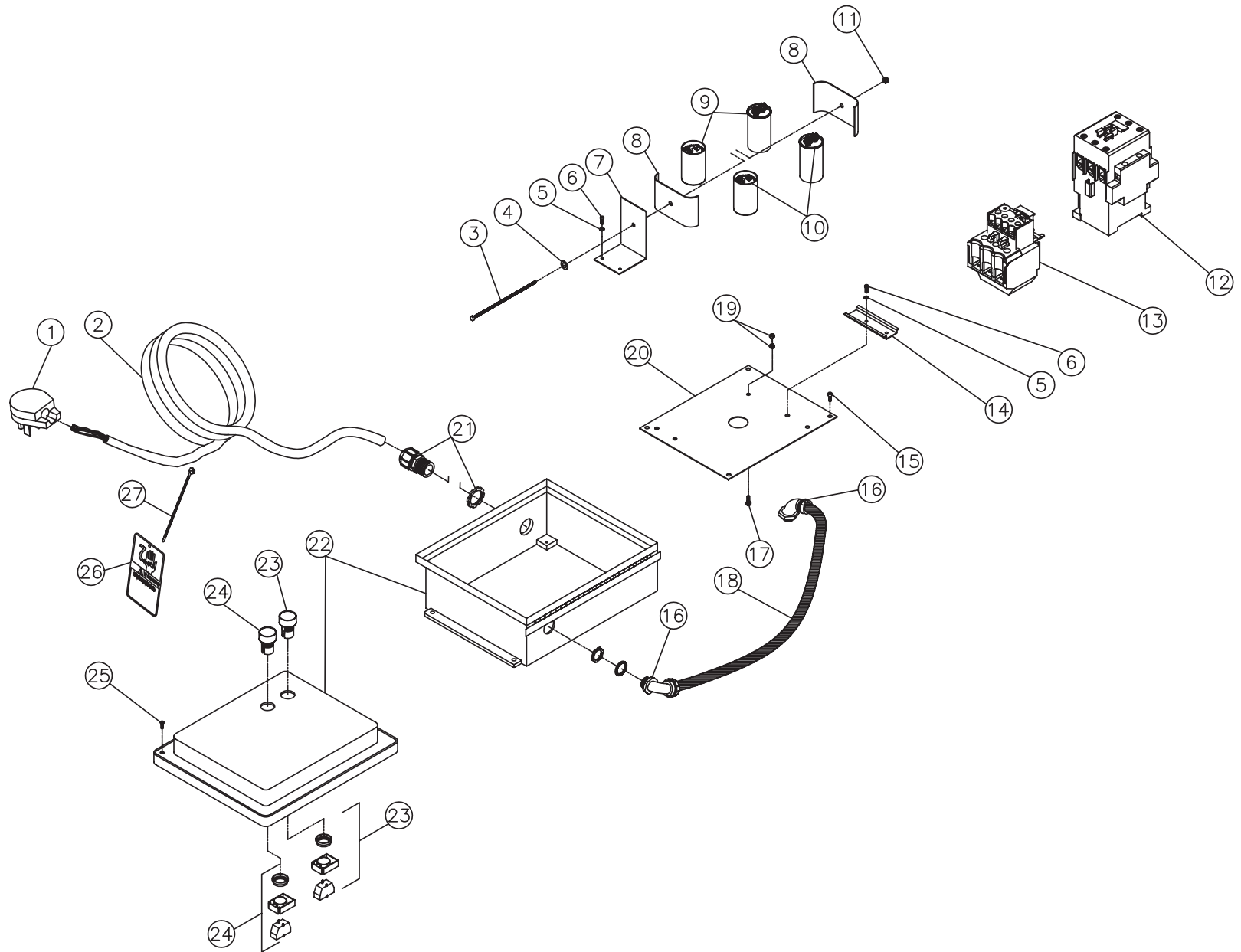

CW-A-0008-092904-AJG

ELECTRIC BOX FOR CW-3005-0ME1 (230 VOLT)								
REF. #	DESCRIPTION	PART #	QTY.		REF. #	DESCRIPTION	PART #	QTY.
1	Plug	32-0012	1		15	Screw w/Electrical Box	27-8922	4
2	Cord *(Ten Feet Required)	32-0021	1		16	Conduit	32-0487	2
3	Bolt	27-0759	1		17	Flange	27-8898	1
4	Washer	28-0001	1		18	Conduit *(Two Feet Required)	32-0486	1
5	Washer	28-0010	4		19	Hex Nut	30-3022	2
6	Bolt	27-8835	4		20	Electrical Panel	20-0557A06	1
7	Capacitor Bracket	20-0556A06	1		21	Cord Strain Relief	32-0040	1
8	Capacitor Clamp	20-0467	2		22	Electrical Box	32-0701	1
9	Capacitors- Silver/Run (w/Motor)	32-0519	2		23	Stop Switch- Red	32-0610	1
10	Capacitors- Black/Start (w/Motor)	32-0516	2		24	Start Switch- Green	32-0534	1
11	Locknut	30-0154	1		25	Screw	27-2930	2
12	Contacto	32-0700	1		26	Tag- Risk of Electrocution	34-1035	1
13	Overload Relay	32-0490	1		27	Cable Tie	33-0022	1
14	Din Rail *(One Foot Required)	32-0316	1		*Must Order in One Foot Lengths			

# WIRING SCHEMATIC FOR CW-3005-0ME1 (230 VOLT)

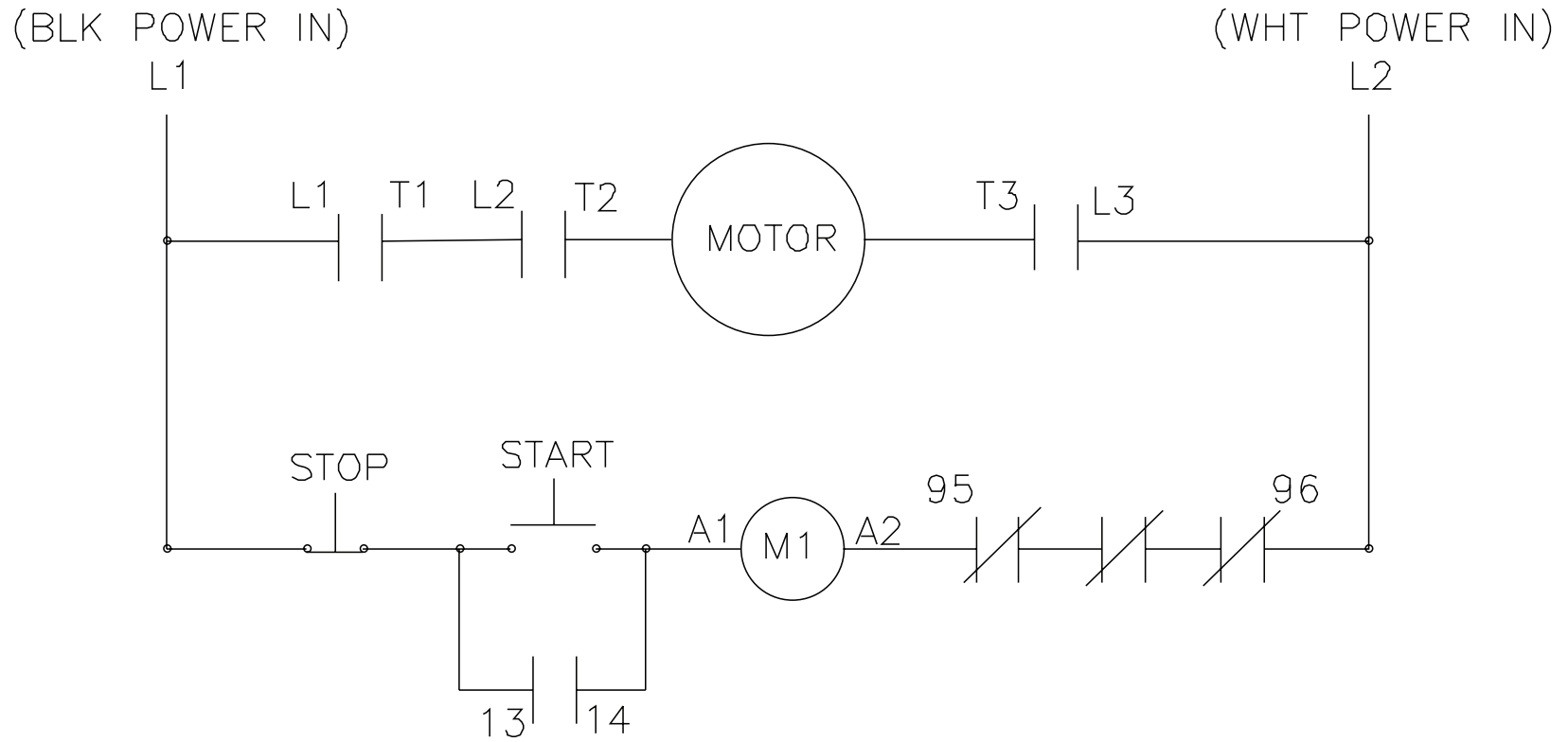

CW-WD-0005-S-120000-GJH



# WIRING DIAGRAM FOR CW-3005-0ME1 (230 VOLT)

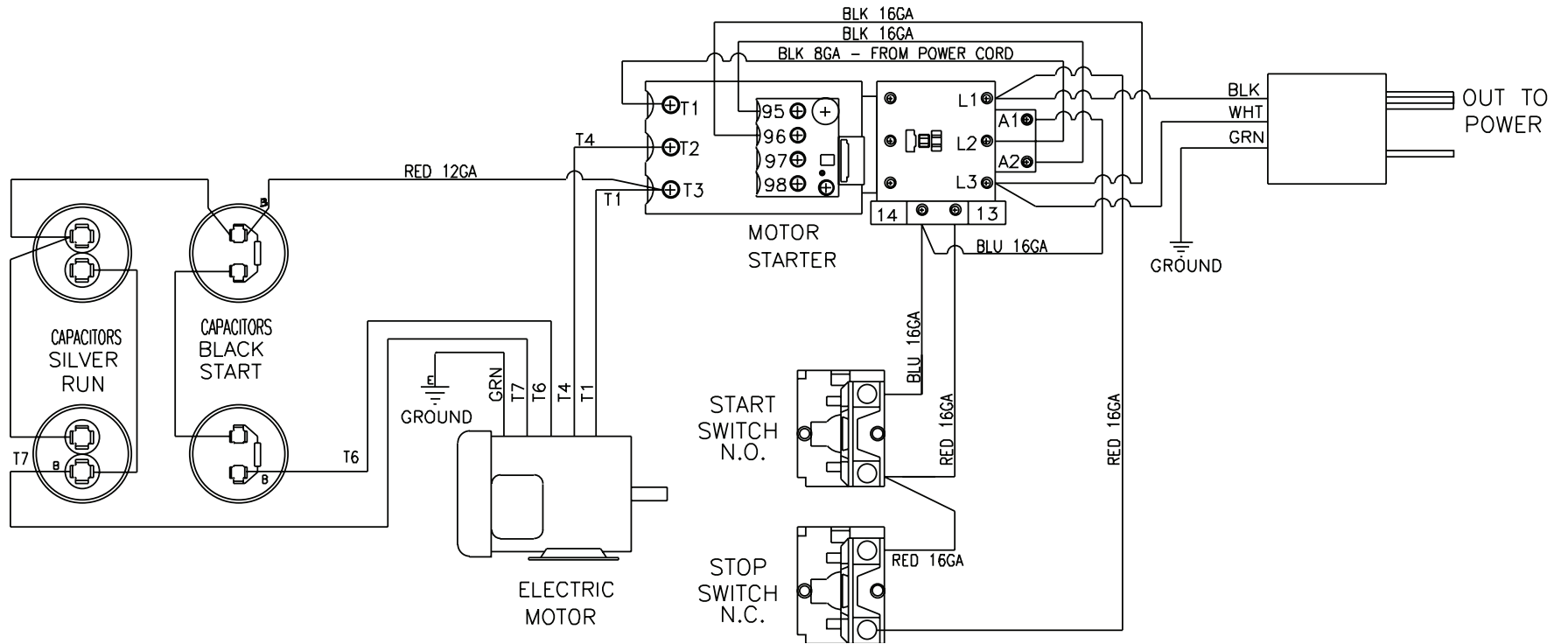

# ELECTRIC BOX FOR CW-3005-0ME3 (230 VOLT)

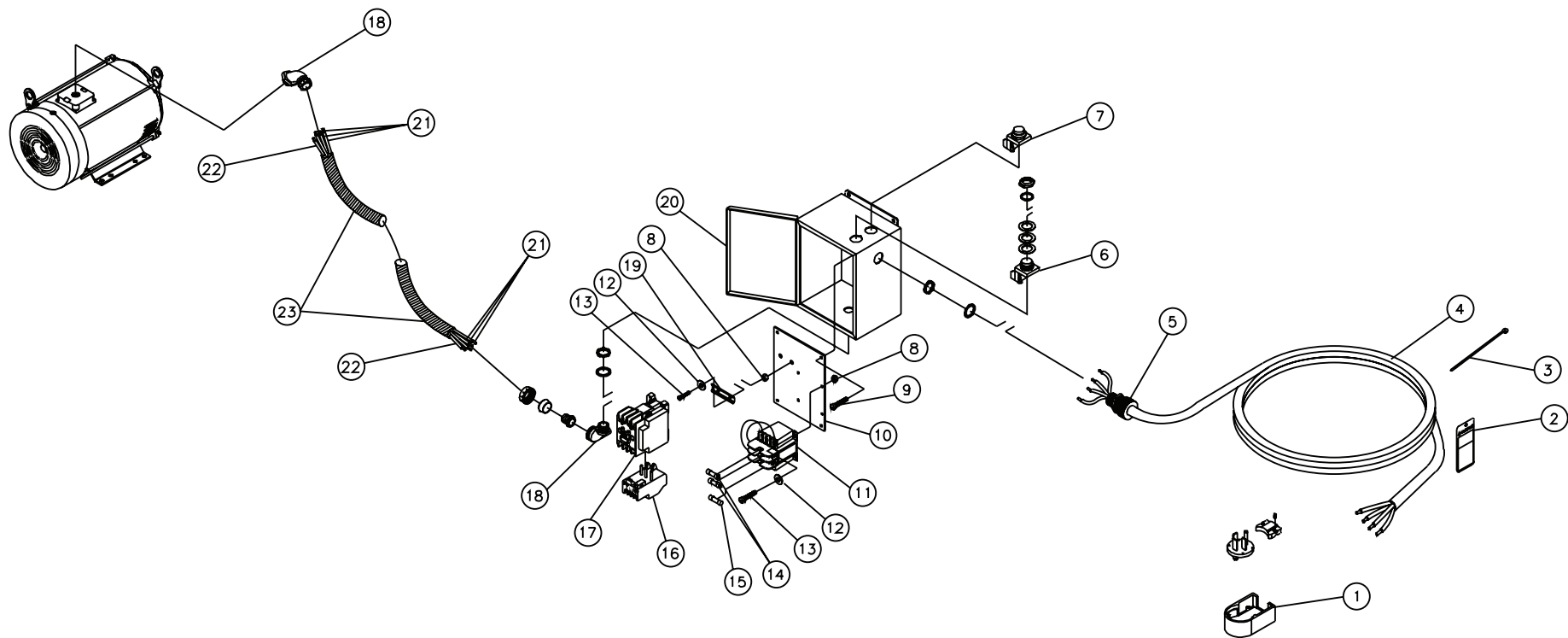

C W-A-0006-042501-RD

ELECTRIC BOX FOR CW-3005-0ME3 (230 VOLT) (BEFORE SERIAL #10154637)								
REF. #	DESCRIPTION	PART #	QTY.		REF. #	DESCRIPTION	PART #	QTY.
1	Plug	32-0647	1		13	Bolt	27-8927	6
2	Tag- Risk of Electrocution	34-0330	1		14	Fuse- 3.5 AMP	32-0469	2
3	Cable Tie	33-0022	1		15	Fuse- 10 AMP	32-0619	1
4	Cord *(Ten Feet Required)	32-0123	1		16	Overload Relay	32-0484	1
5	Cord Strain Relief	32-0040	1		17	Contactora	32-0597	1
6	Stop Switch- Red	32-0306	1		18	Conduit	32-0487	2
7	Start Swich- Green	32-0305	1		19	Din Rail *(One Foot Required)	32-0316	1
8	Locknut	30-8152	6		20	Electrical Box	32-0455	1
9	Bolt (See 32-0455)	N/A Sep.	4		21	Wire- Black *(Six Feet Required)	32-0501	1
10	Panel	32-0456	1		22	Wire- Green *(Two Feet Required)	32-0622	1
11	Transformer	32-0618	1		23	Conduit *(Two Feet Required)	32-0486	1
12	Washer	28-0010	6		*Must Order in One Foot Lengths			

# WIRING SCHEMATIC FOR CW-3005-0ME3 (230 VOLT)

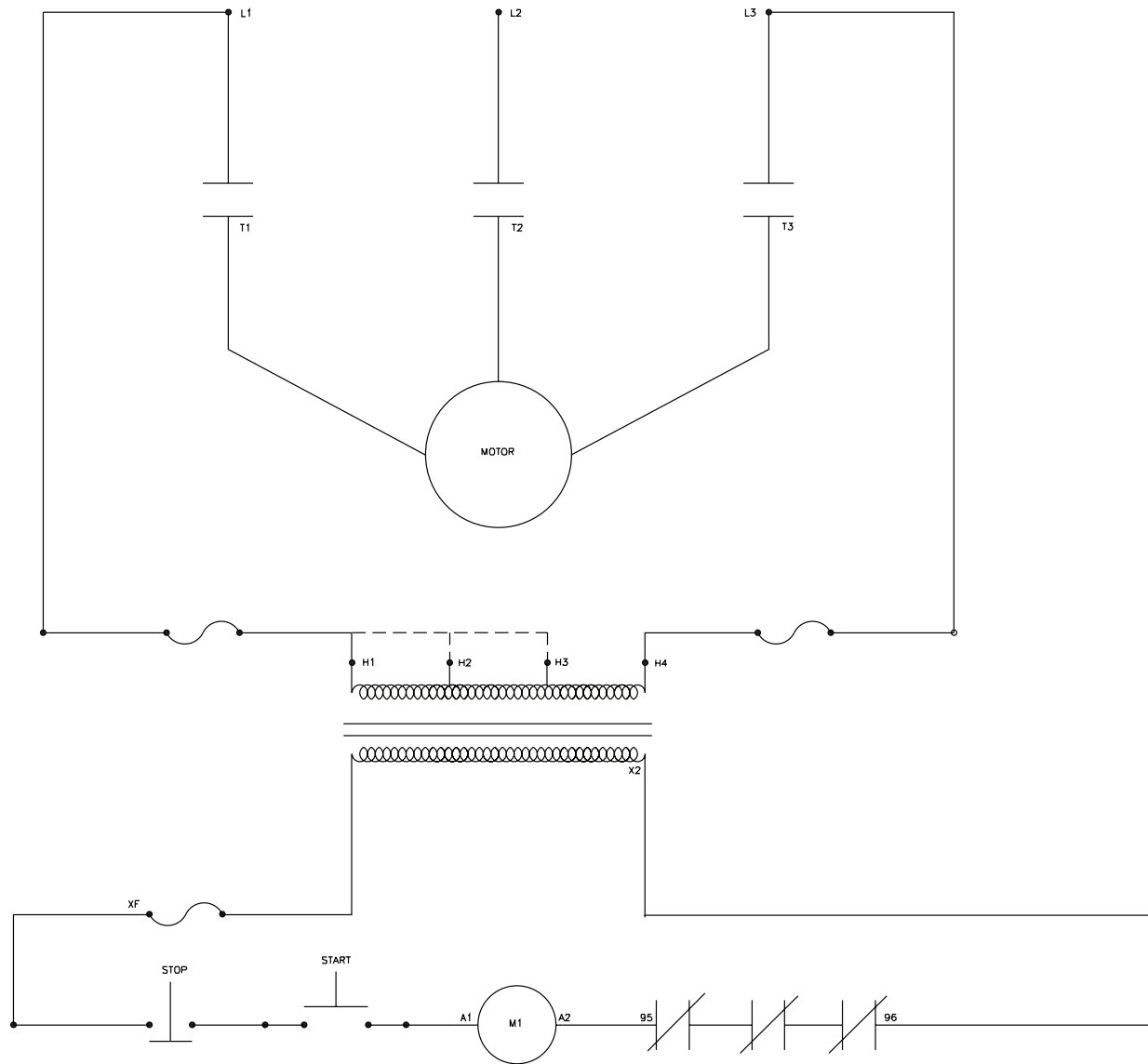

CW-WD-0001-112700-RD

# WIRING DIAGRAM FOR CW-3005-0ME3 (230 VOLT)

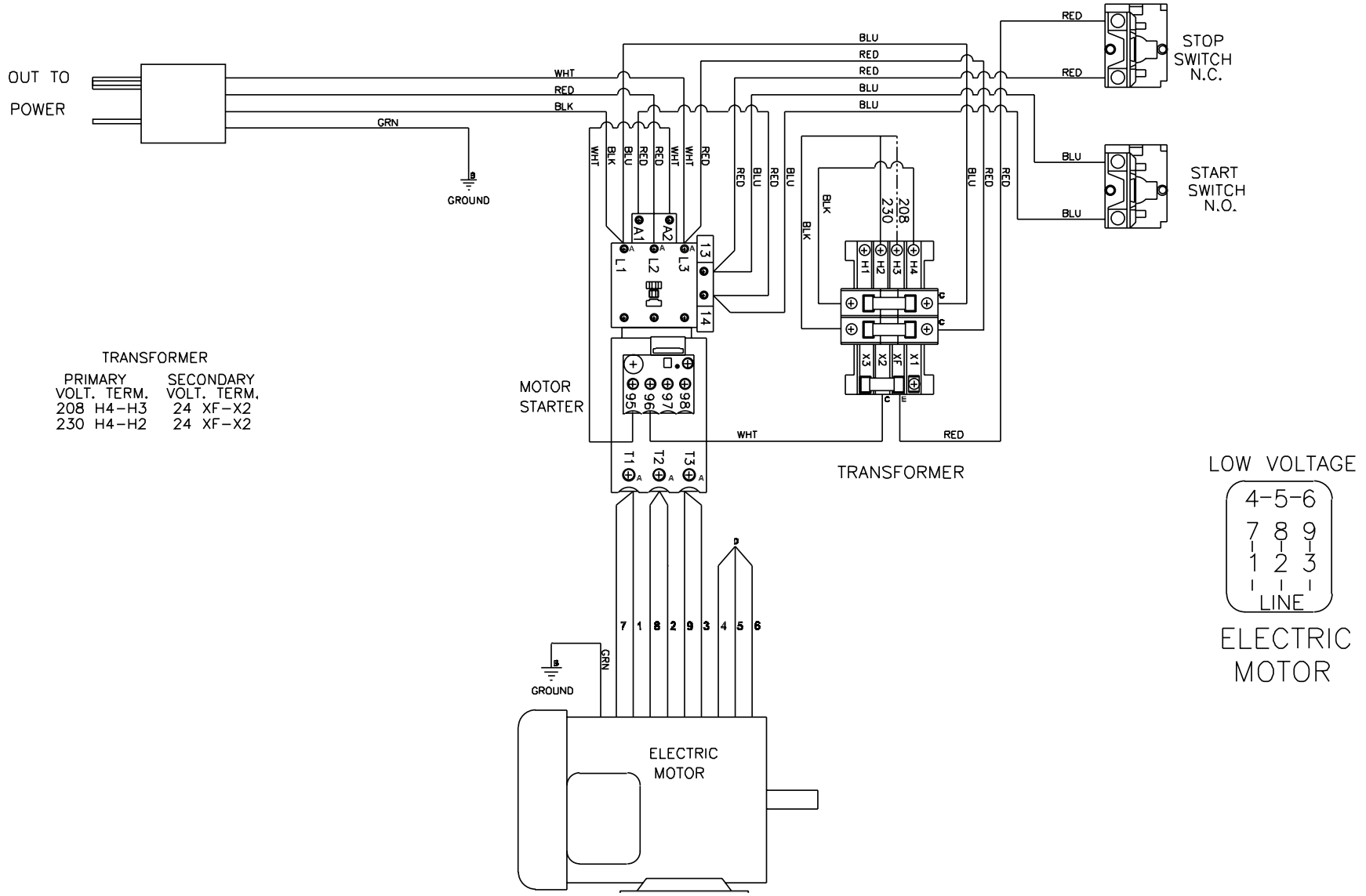

CW-WD-0002-070501-EDW

# ELECTRIC BOX FOR CW-3005-0ME3 (CX-0062 OPTION) (480 VOLT)

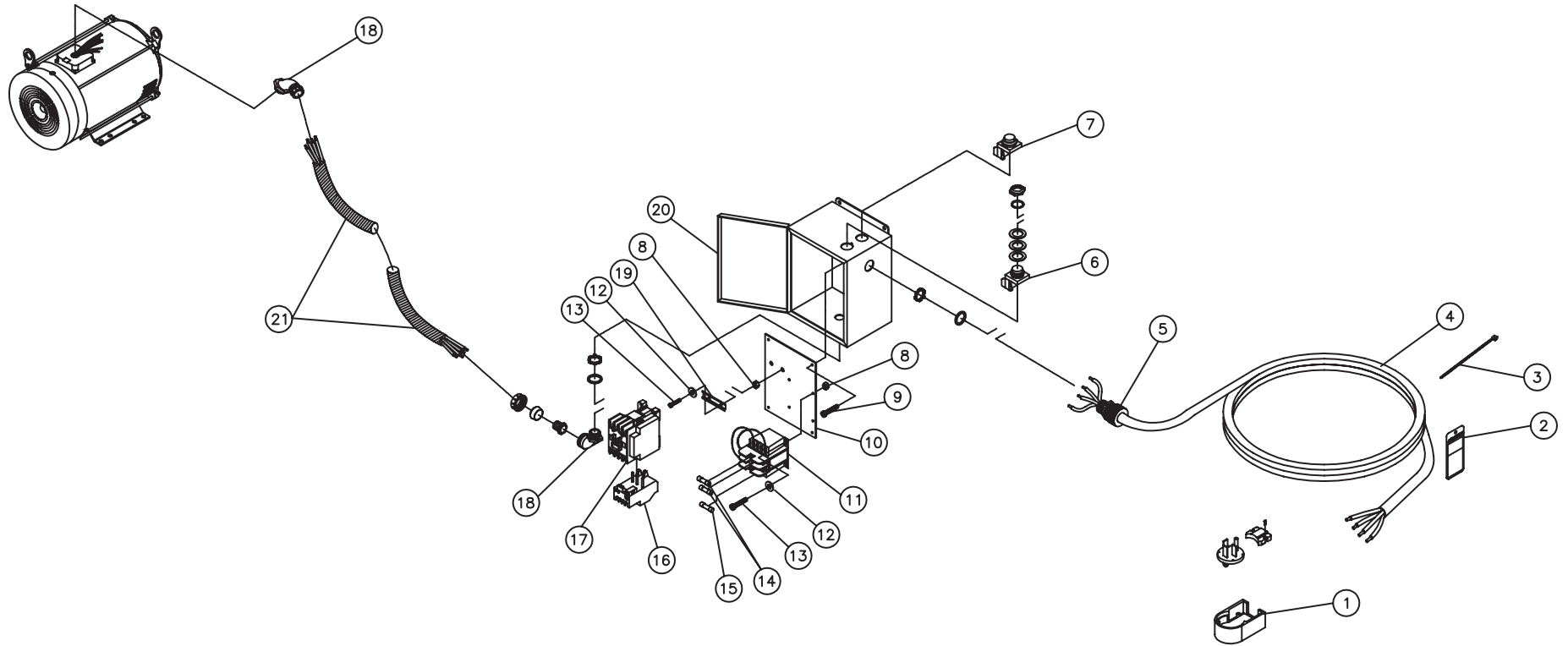

C W-A-0007-092904

ELECTRIC BOX FOR CW-3005-0ME3 (CX-0062 OPTION) (480 VOLT)								
REF. #	DESCRIPTION	PART #	QTY.		REF. #	DESCRIPTION	PART #	QTY.
1	Plug	32-0146	1		12	Washer	28-0010	6
2	Tag- Risk of Electrocutation	34-1035	1		13	Bolt	27-8927	6
3	Cable Tie	33-0022	1		14	Fuse- 1/4 AMP	32-0325	2
4	Cord *(Ten Feet Required)	32-0023	1		15	Fuse- 3 AMP	32-0323	1
5	Cord Strain Relief	9-0046	1		16	Overload Relay	32-0482	1
6	Stop Switch- Red	32-0306	1		17	Contactactor	32-0327	1
7	Start Swich- Green	32-0305	1		18	Conduit	32-0487	2
8	Locknut	30-8152	6		19	Din Rail *(One Foot Required)	32-0316	1
9	Bolt (See 32-0455)	N/A Sep.	4		20	Electrical Box	32-0455	1
10	Panel	32-0456	1		21	Conduit *(Two Feet Required)	32-0486	1
11	Transformer	32-0313	1		*Must Order in One Foot Lengths			

# WIRING SCHEMATIC FOR CW-3005-0ME3 (CX-0062 OPTION) (480 VOLT)

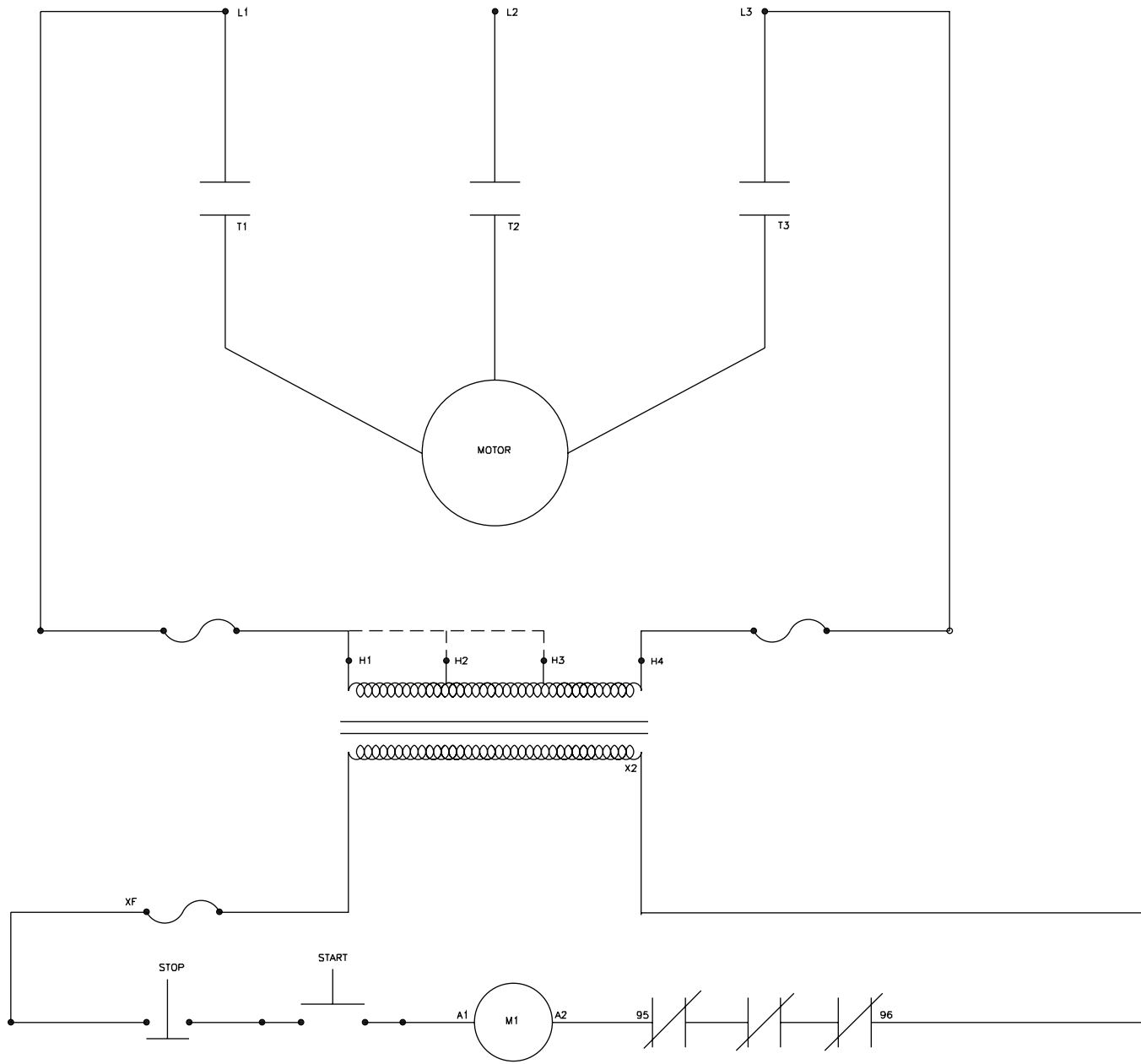

CW-WD-0001-112700-RD



# WIRING DIAGRAM FOR CW-3005-0ME3 (CX-0062 OPTION) (480 VOLT)

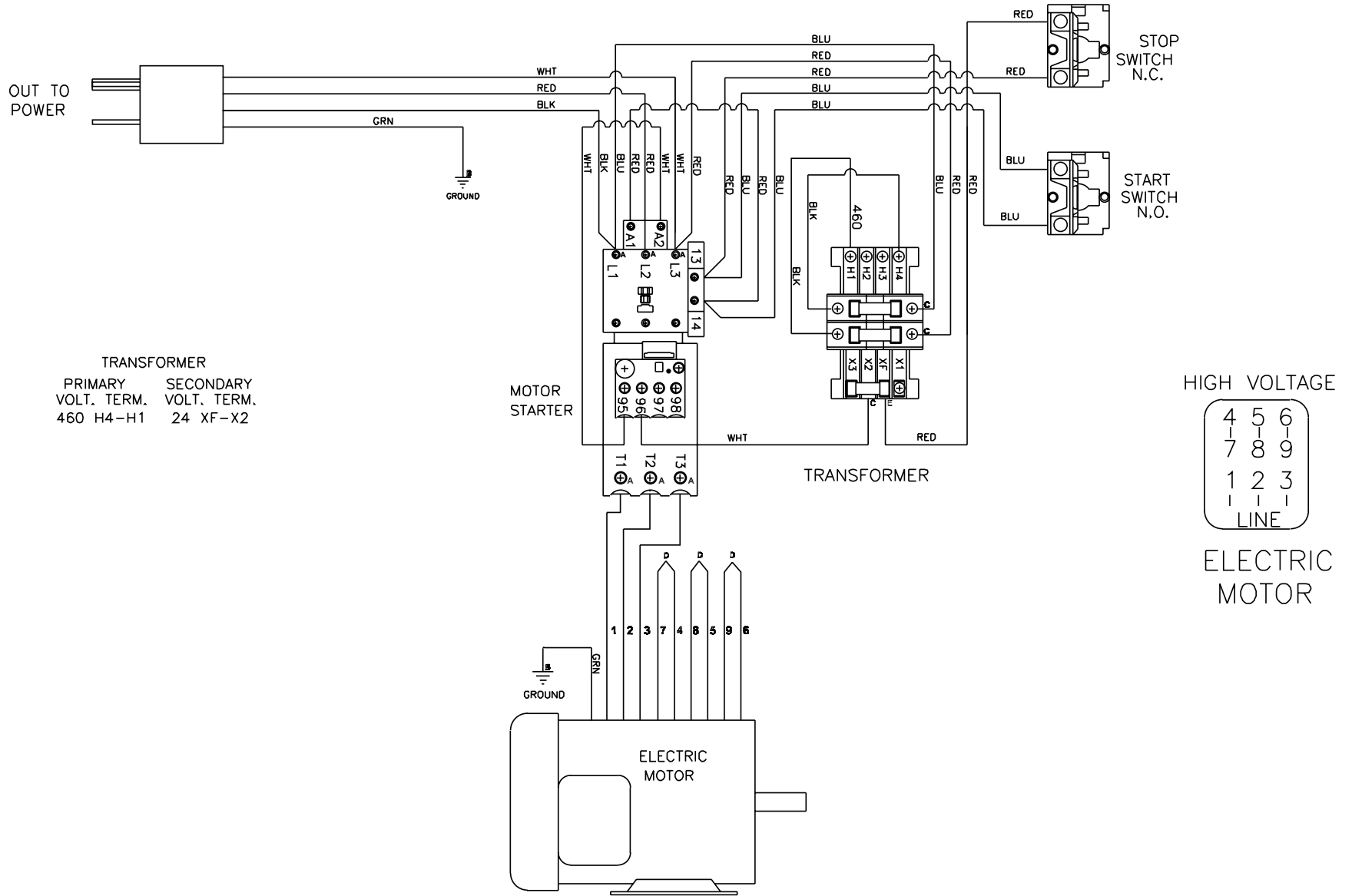

CW-WD-0003-122700-EDW

